

KENWOOD

GPS NAVIGATION SYSTEM

KNA-G421

INSTALLATION MANUAL

Kenwood Corporation



B54-4617-08

Warning

Failure to avoid the following potentially hazardous situations could result in serious injury or fire.

- Do not attempt to install or service the KNA-G421 by yourself. Installing or servicing the unit without training and experience in electronic equipment and automotive accessories may be dangerous and could expose you to the risk of electric shock or other hazards.
- When extending ignition, battery, or ground wires, use automotive-grade wires or other wires with AWG 18 (0.75 mm² gauge) or greater to prevent wire deterioration and damage to the wire coating.
- If the unit starts to emit smoke or strange smells, turn off the power immediately and consult your Kenwood dealer.
- Keep small articles (like screws or batteries) out of the reach of children. If any such object is accidentally swallowed, consult a doctor immediately.

Caution

Failure to avoid the following potentially hazardous situations may result in injury or property damage.

- Make sure to ground the unit to the chassis of your vehicle.
- Secure all wiring with cable clamps or electrical tape. Insulate unconnected wires; do not allow any bare wiring to remain exposed.
- Do not let unconnected wires or terminals touch metal on the vehicle or anything else that can conduct electricity.
- Do not open the top or bottom covers of the unit.
- The KNA-G421 is not waterproof.

What's Included

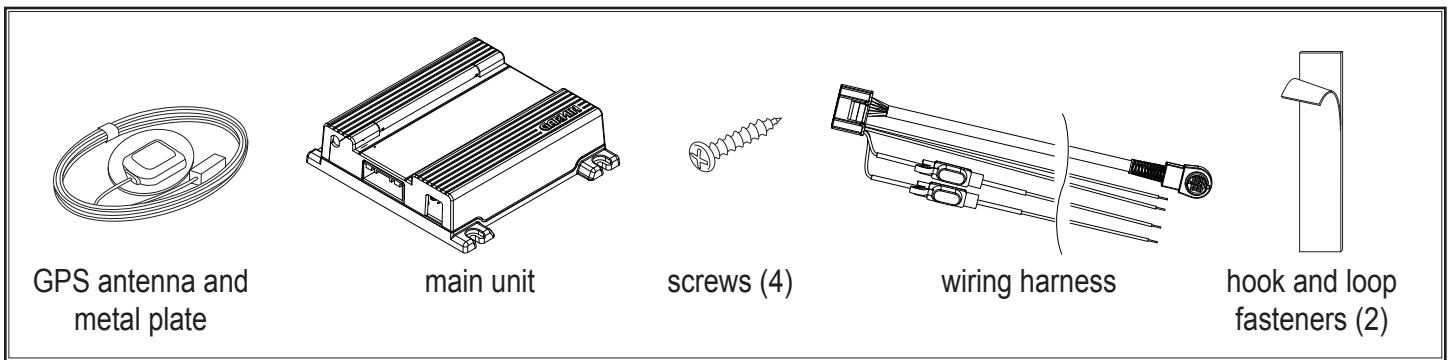

Installing the Main Unit

Use the screws or the hook and loop fasteners provided to mount the main unit in the vehicle. Select a location that allows you to access the unit's SD card slot. Be sure to place the unit horizontally (flat) and secure it completely for best performance.

⚠ Caution

- Do not install the unit where it will be exposed to direct sunlight, excessive heat or humidity, dust, spills, or liquids. Use only the screws provided. If you use the wrong screws, you could damage the unit.
- Check for cables or other parts underneath the floor mat before cutting the floor mat.

Installing the GPS Antenna

⚠ Caution

- Do not paint the antenna. This will impair or disable signal reception.
- Remove any object or accumulated snow, etc., from the top of the antenna. It will reduce reception strength.
- Do not pull the cord when removing the antenna or adjusting its position. This can cause a short or snap the wires.
- The **permanent** adhesive on the back of the metal plate is extremely difficult to remove after it is installed.

The GPS antenna can be installed either inside or outside the vehicle. It should be placed horizontally for best GPS reception. The GPS antenna must have a clear view of the sky. If you install the antenna inside the vehicle, place it close to a window; GPS signals can pass through glass but not through metal. Refer to the image on the next page for recommended places to install the antenna. Place the GPS antenna on a metallic surface, such as the roof of your vehicle, for best reception. If a metallic surface is not available, mount the GPS antenna to the enclosed metal plate. See the next page for further instructions.

Installing Optional Accessories

For information on installing the optional FM traffic receiver (such as the GTM 10), refer to the installation guide included with the traffic receiver.

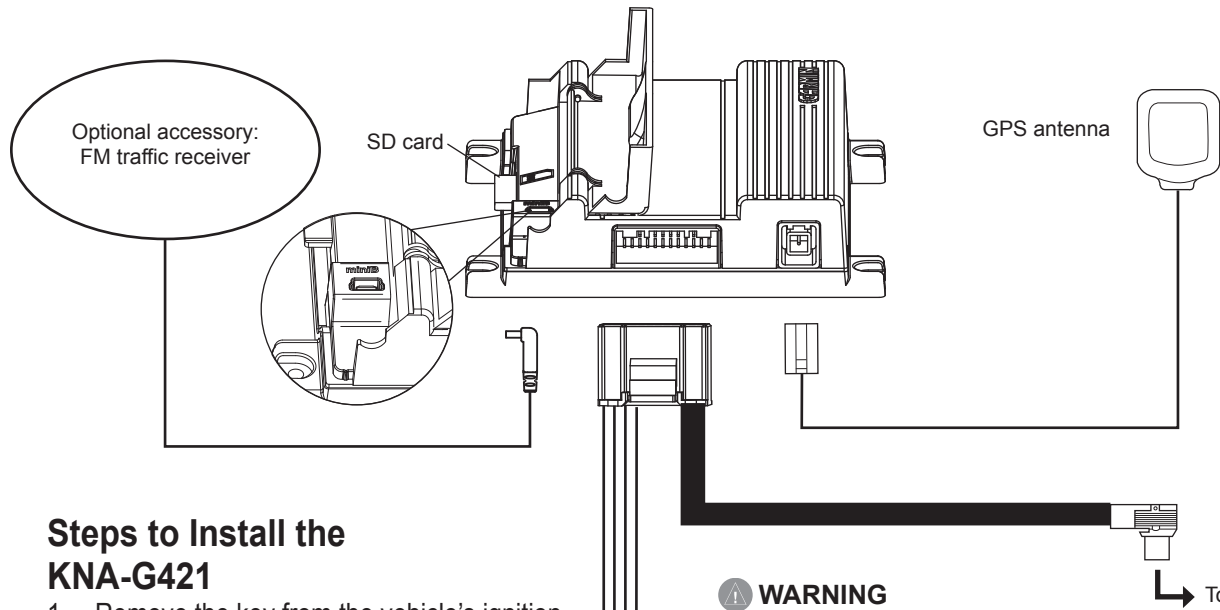

Installing the GPS antenna

Best (roof of vehicle)

Better (trunk of vehicle)

Good (inside car on dashboard)

To mount the GPS antenna inside your vehicle:

1. Clean your dashboard or other surface.
2. Peel the backing off of the adhesive on the bottom of the metal plate.
3. Press the metal plate down firmly on your dashboard or other mounting surface. You can bend the metal plate to conform to a curved surface, if necessary.
4. Place the GPS antenna on top of the metal plate.

Steps to Install the KNA-G421

1. Remove the key from the vehicle's ignition and disconnect the negative battery cable.
2. Install the GPS antenna. Refer to the tips on the previous page.
3. Connect the wiring harness to your vehicle in the following order: ground, battery, ignition.
4. Connect the wiring harness to the main unit.
5. Install the main unit. Refer to the tips on the previous page.
6. Reconnect the negative battery cable.

WARNING

Do not connect the yellow wire lead directly to the vehicle battery. Connecting directly to the battery may cause the wire insulation to fail and may pose a risk of short circuit and electric shock.

WARNING

Be sure to connect the parking brake wire to ensure safe navigation.

CAUTION

If your vehicle's ignition does not have an ACC position, connect the ignition wires to a power source that can be turned on and off with the ignition key. If you connect the ignition wire to a power source with a constant voltage supply, as with battery wires, the vehicle's battery may die.

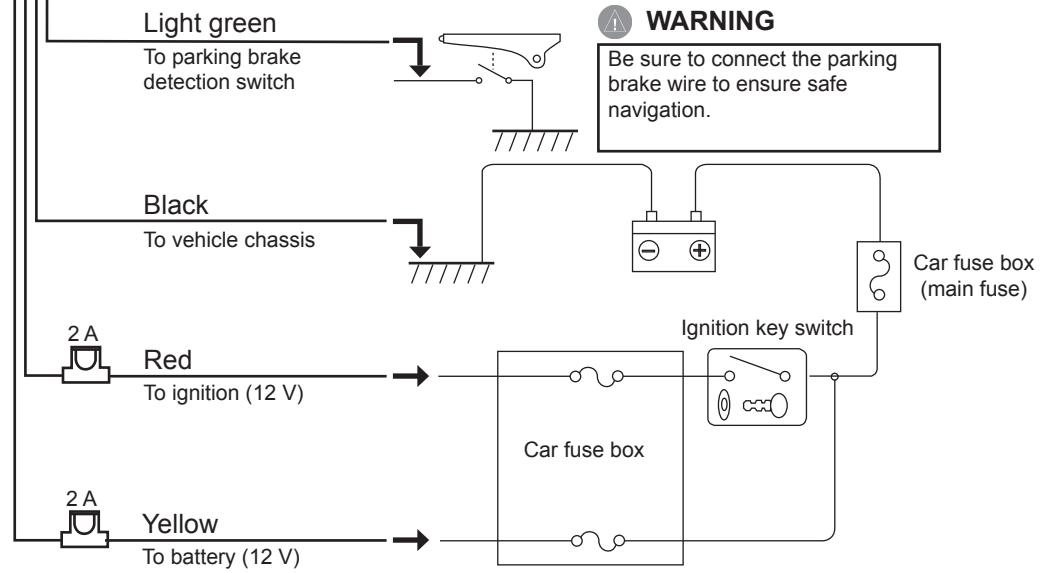

Acquiring GPS Signals

The first time you turn on the KNA-G421, you must wait while the system acquires satellite signals for the first time. This process could take up to several minutes. Make sure your vehicle is outdoors in an open area away from tall buildings and trees for fastest acquisition. After the system acquires satellites for the first time, it will acquire satellites quickly each time thereafter.

Changing the Fuses

If you need to replace a fuse on the red or yellow wires, make sure the wires are not touching to prevent a short circuit. Then replace the old fuse with a new 2 Amp fuse.

Caution

When replacing a fuse, use only a new fuse with the prescribed rating. Using a fuse with the wrong rating may cause your unit to malfunction. Disconnect the wiring harness before replacing a fuse to prevent short circuits.

Specifications

General

Operating Temperature: -15°C to 70°C

Storage Temperature: -40°C to 85°C

Operating Voltage: 9.5 V to 25 V

Current Consumption: 0.13 A typical at 13 V (Max 1.0 A at 13 V)

ACC off Current: 60 uA typical at 13 V

Dimensions: 30 mm H x 120 mm W x 117 mm L

Weight: 184 g

Map Storage: Internal non-removable memory and optional removable SD card (City Navigator™ map data)

Connectors: System/power, GPS antenna, SD card slot, Mini-B for optional FM traffic receiver

Navigation

Receiver: SiRF STAR III high-sensitivity GPS receiver

Frequency: 1,575.42 MHz

Acquisition Times*:

Warm: < 1 second

Cold: < 38 seconds

AutoLocate®: < 45 seconds

*On average for a stationary receiver with an open sky view

Update Rate: 1/second, continuous

GPS Accuracy:

Position: < 10 meters, typical

Velocity: 0.05 meter/sec RMS

DGPS (WAAS) Accuracy:

Position: < 5 meters, typical

Velocity: 0.05 meter/sec RMS

Antenna:

External GPS antenna requires metal surface 60 mm x 60 mm or larger, such as a car roof or the included metal plate. A larger metal mounting surface improves GPS reception.