

KENWOOD

KDC-4757SD KDC-3657SD

CD-RECEIVER

INSTRUCTION MANUAL

CD-RECEIVER

BEDIENUNGSANLEITUNG

CD-РЕСИВЕР

ИНСТРУКЦИЯ ПО ЭКСПЛУАТАЦИИ

CD-РЕСИВЕР

ІНСТРУКЦІЯ З ЕКСПЛУАТАЦІЇ

JVC KENWOOD Corporation



Изделие изготовлено во Франции

© 2012 JVC KENWOOD Corporation



GET0857-004A (EF)

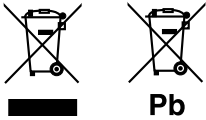

Information on Disposal of Old Electrical and Electronic Equipment and Batteries (applicable for EU countries that have adopted separate waste collection systems)

Products and batteries with the symbol (crossed-out wheeled bin) cannot be disposed as household waste.

Old electrical and electronic equipment and batteries should be recycled at a facility capable of handling these items and their waste byproducts.

Contact your local authority for details in locating a recycle facility nearest to you.

Proper recycling and waste disposal will help conserve resources whilst preventing detrimental effects on our health and the environment.

Notice: The sign "Pb" below the symbol for batteries indicates that this battery contains lead.

Entsorgung von gebrauchten elektrischen und elektronischen Geräten und Batterien (anzuwenden in den Ländern der Europäischen Union und anderen europäischen Ländern mit einem separaten Sammelsystem für solche Geräte)

Das Symbol (durchgestrichene Mülltonne) auf dem Produkt oder seiner Verpackung weist darauf hin, dass dieses Produkt nicht als normaler Haushaltsabfall behandelt werden darf, sondern an einer Annahmestelle für das Recycling von elektrischen und elektronischen Geräten und Batterien abgegeben werden muss.

Durch Ihren Beitrag zur korrekten Entsorgung dieses Produktes schützen Sie die Umwelt und die Gesundheit Ihrer Mitmenschen.

Unsachgemäße oder falsche Entsorgung gefährden Umwelt und Gesundheit.

Weitere Informationen über das Recycling dieses Produktes erhalten Sie von Ihrer Gemeinde oder den kommunalen Entsorgungsbetrieben.

Achtung: Das Zeichen „Pb“ unter dem Symbol für Batterien zeigt an, dass diese Batterie Blei enthält.



Declaration of Conformity with regard to the EMC Directive 2004/108/EC

Manufacturer:

JVC KENWOOD Corporation

3-12, Moriya-cho, Kanagawa-ku, Yokohama-shi, Kanagawa, 221-0022, Japan

EU Representative's:

Kenwood Electronics Europe BV

Amsterdamseweg 37, 1422 AC UITHOORN, The Netherlands

Konformitätserklärung in Bezug auf die EMC-Vorschrift 2004/108/EC

Hersteller:

JVC KENWOOD Corporation

3-12, Moriya-cho, Kanagawa-ku, Yokohama-shi, Kanagawa, 221-0022, Japan

EU-Vertreter:

Kenwood Electronics Europe BV

Amsterdamseweg 37, 1422 AC UITHOORN, Niederlande

This Product is not installed by the manufacturer of a vehicle on the production line, nor by the professional importer of a vehicle into an EU Member State.

Dieses Produkt wird weder vom Hersteller eines Fahrzeugs während der Produktion noch von einem professionellen Importeur eines Fahrzeugs in einen EU-Mitgliedsstaat eingebaut.



The marking of products using lasers

The label is attached to the chassis/case and says that the component uses laser beams that have been classified as Class 1. It means that the unit is utilizing laser beams that are of a weaker class. There is no danger of hazardous radiation outside the unit.

Kennzeichnung von Geräten mit Laser-Abtastern

Das Etikett ist am Chassis/Gehäuse angebracht und besagt, dass sich die Komponente Laserstrahlen bedient, die als Laserstrahlen der Klasse 1 klassifiziert wurden. Dies weist darauf hin, dass sich das Gerät Laserstrahlen bedient, die einer schwächeren Klasse angehören. Das bedeutet, dass durch den sehr schwachen Laserstrahl keine Gefahr durch gefährliche Strahlungen außerhalb des Geräts besteht.

Маркировка изделий, использующих лазеры

К корпусу устройства прикреплена табличка, указывающая, что устройство использует лазерные лучи класса 1. Это означает, что в устройстве используются лазерные лучи слабой интенсивности. Они не представляют опасности и не распространяют опасную радиацию вне устройства.

Маркування виробів, обладнаних лазером

На каркас/корпус поміщається наклейка, в якій зазначається, що даний виріб випромінює лазерні промені Класу 1. Це означає, що даний апарат використовує лазерні промені слабшого класу. За межами даного апарату не існує небезпеки лазерного випромінювання.

При Правильном соблюдении всех условий эксплуатации и технических требований, указанных в данной инструкции, срок службы купленного Вами изделия составляет 7 лет. Гарантийный срок эксплуатации изделия соответствует сроку, указанному в гарантийном талоне. В период срока службы эксплуатация и хранение изделия не может представлять опасность для Вашей жизни, здоровья, причинять вред Вашему имуществу или окружающей среде.

Декларація про Відповідність Вимогам Технічного Регламенту Обмеження Використання деяких Небезпечних Речовин в електричному та електронному обладнанні (затвердженого Постановою №1057 Кабінету Міністрів України)

Виріб відповідає вимогам Технічного Регламенту Обмеження Використання деяких Небезпечних Речовин в електричному та електронному обладнанні (ТР ОБНР).

Вміст небезпечних речовин у випадках, не обумовлених в Додатку №2 ТР ОБНР:

1. свинець(Pb) – не перевищує 0.1 % ваги речовини або в концентрації до 1000 частин на мільйон;
2. кадмій (Cd)– не перевищує 0.01 % ваги речовини або в концентрації до 100 частин на мільйон;
3. ртуть(Hg) – не перевищує 0.1 % ваги речовини або в концентрації до 1000 частин на мільйон;
4. шестивалентний хром (Cr 6+) – не перевищує 0.1 % ваги речовини або в концентрації до 1000 частин на мільйон;
5. полібромбіфеноли (ПВВ) – не перевищує 0.1% ваги речовини або в концентрації до 1000 частин на мільйон;
6. полібромдифенілові ефіри (PBDE) – не перевищує 0.1 % ваги речовини або в концентрації до 1000 частин на мільйон.

For Turkey

Bu ürün 28300 sayılı Resmi Gazete’de yayımlanan Atık Elektrikli ve Elektronik Eşyaların Kontrolü Yönetmeliğe uygun olarak üretilmiştir.

Eski Elektrik ve Elektronik Ekipmanların İmha Edilmesi Hakkında Bilgi (ayrı atık toplama sistemlerine kullanan ülkeleri için uygulanabilir)



Sembollü (üzerinde çarpı işareti olan çöp kutusu) ürünler ev atıkları olarak atılamaz.

Eski elektrik ve elektronik ekipmanlar, bu ürünleri ve ürün atıklarını geri dönüştürebilecek bir tesiste değerlendirilmelidir. Yaşadığınız bölgeye en yakın geri dönüşüm tesisinin yerini öğrenmek için yerel makamlara müracaat edin. Uygun geri dönüşüm ve atık imha yöntemi sağlığımız ve çevremiz üzerindeki zararlı etkileri önlerken kaynakların korunmasına da yardımcı olacaktır.

CONTENTS

BEFORE USE	2
BASICS	3
GETTING STARTED	4
RADIO	5
CD / USB / SD / iPod	6
AUX	7
AUDIO SETTINGS	8
DISPLAY SETTINGS	9
MORE INFORMATION	9
TROUBLESHOOTING	10
SPECIFICATIONS	11
INSTALLATION / CONNECTION	12

How to read this manual

- Operations explained mainly using buttons on the faceplate.
- [XX] indicates the selected items.
- (→ XX) indicates references are available on the stated page number.

BEFORE USE

⚠ Warning

Do not operate any function that takes your attention away from safe driving.

⚠ Caution

Volume setting:

- Adjust the volume so that you can hear sounds outside the car to prevent accident.
- Lower the volume before playing digital sources to avoid damaging the speakers by the sudden increase of the output level.

General:

- Avoid using the USB device or iPod/iPhone if it might hinder driving safety.
- Make sure all important data has been backed up. We shall bear no responsibility for any loss of recorded data.
- Never put or leave any metallic objects (such as coins or metal tools) inside the unit, to prevent a short circuit.
- If a disc error occurs due to condensation on the laser lens, eject the disc and wait for the moisture to evaporate.

Maintenance

Cleaning the unit: Wipe off dirt on the faceplate with a dry silicon or soft cloth.

Cleaning the connector: Detach the faceplate and clean the connector with a cotton swab gently, being careful not to damage the connector.

Handling discs:

- Do not touch the recording surface of the disc.
- Do not stick tape etc. on the disc, or use a disc with tape stuck on it.
- Do not use any accessories for the disc.
- Clean from the center of the disc and move outward.
- Clean the disc with a dry silicon or soft cloth. Do not use any solvents.
- When removing discs from this unit, pull them out horizontally.
- Remove burrs from the center hole and disc edge before inserting a disc.

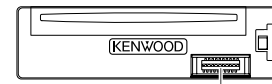

Connector (on the reverse side of the faceplate)

BASICS

Faceplate

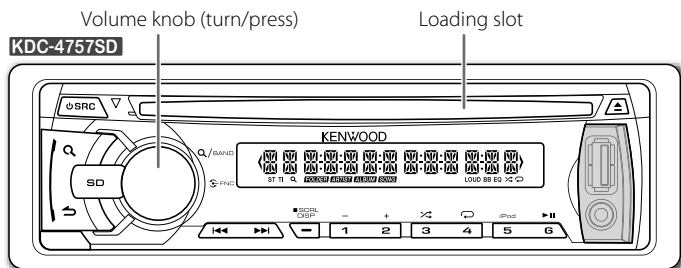

KDC-4757SD

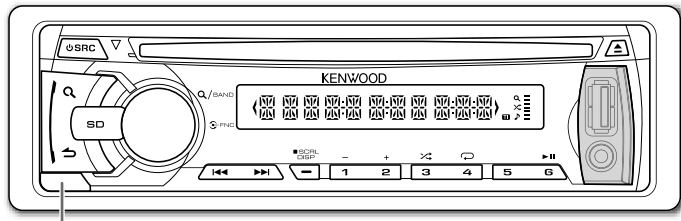

Detach button

Attach

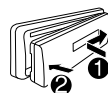

Detach

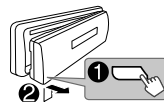

How to reset

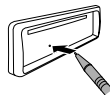

Your preset adjustments will also be erased.

Insert an SD card

- 1 Press **SRC** to turn off the power.
- 2 Detach the faceplate.
- 3 Insert the SD card into the SD CARD slot until it clicks.
(With the label side up and the notched section on the right.)

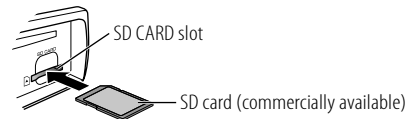

- 4 Reattach the faceplate.

Removing an SD card

- 1 Detach the faceplate.
- 2 Push the SD card until it clicks and then pull it out.
- 3 Reattach the faceplate.

To

Do this (on the faceplate)

Turn on the power

Press **SRC**.
• Press and hold to turn off the power.

Adjust the volume

Turn the volume knob.

Select a source

Press **SRC** repeatedly.

Change the display information

Press **SCRL DISP** repeatedly.
• Press and hold to scroll the current display information.

GETTING STARTED

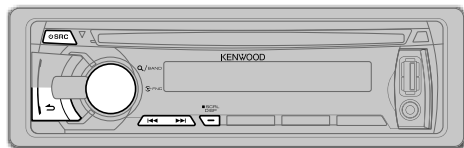

1 Cancel the demonstration

When you turn on the power (or after you reset the unit), the display shows: "CANCEL DEMO" → "PRESS" → "VOLUME KNOB"

- 1 Press the volume knob.
[YES] is selected for the initial setup.
- 2 Press the volume knob again.
"DEMO OFF" appears.

2 Set the clock

- 1 Press the volume knob to enter [FUNCTION].
- 2 Turn the volume knob to select [SETTINGS], then press the knob.
- 3 Turn the volume knob to select [CLOCK], then press the knob.
- 4 Press the volume knob to select [CLOCK ADJUST] / [CLOCK ADJ].
- 5 Turn the volume knob to adjust the hour, then press the knob.
- 6 Turn the volume knob to adjust the minute, then press the knob.
Press ◀▶ to move between the hour and minute adjustment.
- 7 Press and hold ↵ to exit.

(or)

Press and hold **SCRL DISP** to enter clock adjustment mode directly while in clock display screen.
Then, perform steps **5** and **6** above to set the clock.

3 Set the initial settings

- 1 Press **SRC** to enter [STANDBY].
- 2 Press the volume knob to enter [FUNCTION].
- 3 Turn the volume knob to select [INITIAL SET], then press the knob.
- 4 Turn the volume knob to make a selection (see the table below), then press the knob.
- 5 Press and hold ↵ to exit.

• To return to the previous hierarchy, press ↵.

Default: **XX**

PRESET TYPE **NORMAL/ NORM:** Memorizes one station for each preset button in each band (FM1/ FM2/ FM3/ MW/ LW). ; **MIX:** Memorizes one station for each preset button regardless of the selected band.

KEY BEEP **ON:** Activates the keypress tone. ; **OFF:** Deactivates.

RUSSIAN SET **ON:** Folder name, file name, song title, artist name, album name are displayed in Russian (if applicable). ; **OFF:** Cancels.

P-OFF WAIT Applicable only when the demonstration mode is turned off.
Sets the duration when the unit will automatically turns off (while in standby mode) to save the battery.
----: Cancels ; **20M:** 20 minutes ; **40M:** 40 minutes ; **60M:** 60 minutes

BUILT-IN AUX/ BUILT IN AUX **ON:** Enables AUX in source selection. ; **OFF:** Disables. (→ 7)

CD READ **1:** Automatically distinguishes between audio file disc and music CD. ; **2:** Forces to play as a music CD. No sound can be heard if an audio file disc is played.

SWITCH PRE For **KDC-3657SD**:
REAR/ SUB-W: Selects whether rear speakers or a subwoofer are connected to the line out terminals on the rear (through an external amplifier).

SP SELECT **OFF/ 5/4/ 6 × 9/6/ OEM:** Selects according to the speaker size (5 inches or 4 inches, 6×9 inches or 6 inches) or OEM speakers for optimum performance.

F/W UPDATE

F/W UP xx.xx **YES:** Starts upgrading the firmware. ; **NO:** Cancels (upgrading is not activated).
For details on how to update the firmware, see: www.kenwood.com/cs/ce/

RADIO

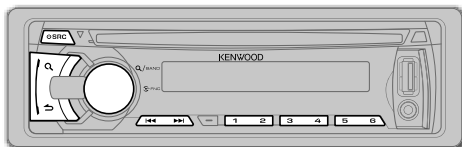

Search for a station

- 1 Press **SRC** to select TUNER.
 - 2 Press **Q** repeatedly to select FM1/ FM2/ FM3/ MW/ LW.
 - 3 Press **◀▶** to search for a station.
- **To store a station:** Press and hold one of the number buttons (1 to 6).
 - **To select a stored station:** Press one of the number buttons (1 to 6)

Other settings

- 1 Press the volume knob to enter [FUNCTION].
- 2 Turn the volume knob to select [SETTINGS], then press the knob.
- 3 Turn the volume knob to make a selection (see the following table), then press the knob.
- 4 Press and hold **↶** to exit.

Default: **XX**

LOCAL SEEK	ON: Searches only FM stations with good reception. ; OFF: Cancels.
SEEK MODE	Selects the tuning method for the ◀▶ buttons. AUTO1: Automatically searches for a station. ; AUTO2: Searches for a preset station. ; MANUAL: Manually search for a station.
AUTO MEMORY	YES: Automatically starts memorizing 6 stations with good reception. ; NO: Cancels. (Selectable only if [NORMAL]/ [NORM] is selected for [PRESET TYPE].) (→ 4)
MONO SET	ON: Improves the FM reception, but the stereo effect may be lost. ; OFF: Cancels.

PTY SEARCH	Selects the available Program Type (see below), then, press ◀▶ to start. Press the volume knob to enter PTY language selection. Turn the volume knob to select the PTY language (ENGLISH/ FRENCH/ GERMAN), then press the knob.
TI	ON: Allows the unit to temporarily switch to Traffic Information. ; OFF: Cancels.
NEWS SET	00M – 90M: Sets the time for receiving the next news bulletin. ; OFF: Cancels.
AF SET	ON: Automatically searches for another station broadcasting the same program in the same Radio Data System network with better reception when the current reception is poor. ; OFF: Cancels.
REGIONAL	ON: Switches to another station only in the specific region using the “AF” control. ; OFF: Cancels.
AUTO TP SEEK/ ATP SEEK	ON: Automatically searches for a station with better reception when the traffic information’s reception is poor. ; OFF: Cancels.

CLOCK

TIME SYNC **ON:** Synchronizes the unit’s time to the Radio Data System station time. ; **OFF:** Cancels.

TUNER SET: Selectable only when the source is not TUNER.

TI/ NEWS SET/ AF SET/ REGIONAL/ AUTO TP SEEK/ ATP SEEK: (For details, refer to the table above.)

- **[LOCAL SEEK]/ [MONO SET]/ [PTY SEARCH]/ [TI]/ [NEWS SET]/ [AF SET]/ [REGIONAL]/ [AUTO TP SEEK]/ [ATP SEEK]** is selectable only when the source is FM.
 - Available Program Type:
SPEECH: **NEWS, AFFAIRS, INFO** (information), **SPORT, EDUCATE, DRAMA, CULTURE, SCIENCE, VARIED, WEATHER, FINANCE, CHILDREN, SOCIAL, RELIGION, PHONE IN, TRAVEL, LEISURE, DOCUMENT**
MUSIC: **POP M** (music), **ROCK M** (music), **EASY M** (music), **LIGHT M** (music), **CLASSICS, OTHER M** (music), **JAZZ, COUNTRY, NATION M** (music), **OLDIES, FOLK M** (music)
- The unit will search for the Program Type categorized under [SPEECH] or [MUSIC] if selected.
- If the volume is adjusted during reception of traffic information, alarm or news bulletin, the adjusted volume is memorized automatically. It will be applied the next time traffic information, alarm or news bulletin function is turned on.

CD / USB / SD / iPod

Start playback

CD

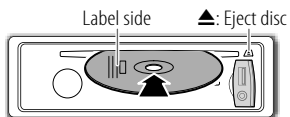

The source changes to CD and playback starts.

USB

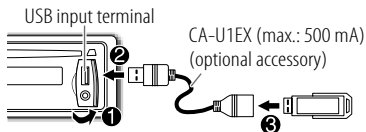

The source changes to USB and playback starts.

iPod/iPhone (for **KDC-4757SD**)

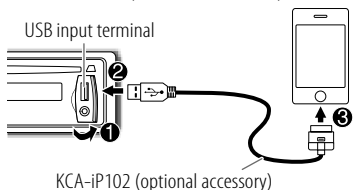

The source changes to iPod and playback starts.

Press **5 iPod** to select the control mode while in iPod source.

MODE ON: From the iPod*1.

MODE OFF: From the unit.

*1 You can still control play/pause, file selection, fast-forward or reverse files from the unit.

Press **SD** to start playback if an SD card is inserted.

- To insert or remove the SD card, (→ 3).

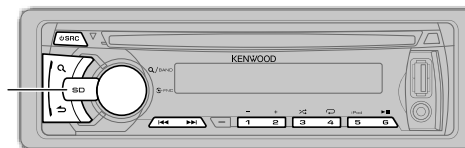

✓ : Applicable
— : Not applicable

To	Do this	CD	USB/SD	iPod
Pause or resume playback	Press 6 ▶ II .	✓	✓	✓
Select a track/file	Press 1 ◀◀ / ▶▶ 1 .	✓	✓	✓
Select a folder	Press 1 - / 2 + .	✓*2	✓	—
Reverse/Fast-forward	Press and hold 1 ◀◀ / ▶▶ 1 .	✓	✓	✓
Select a track/file from a list	<p>1 Press Q.</p> <p>2 Turn the volume knob to make a selection, then press the knob.</p> <ul style="list-style-type: none"> AAC/MP3/WMA file: Select the desired folder, then a file. iPod or KENWOOD Music Editor Light (KME Light)/ KENWOOD Music Control (KMC) file*4: Select the desired file from the list (PLAYLISTS, ARTISTS, ALBUMS, SONGS, PODCASTS*5, GENRES, COMPOSERS*5). <p>To return to the root folder (or first file), press number button 5.</p> <p>To return to the previous hierarchy, press ↶.</p> <p>To cancel, press and hold ↶.</p>	✓	✓	✓*3
Repeat play	<p>Press 4 ↻ repeatedly.</p> <ul style="list-style-type: none"> Audio CD: TRACK/ TRAC REPEAT, REPEAT OFF AAC/MP3/WMA file: FILE REPEAT, FOLDER/ FOLD REPEAT, REPEAT OFF iPod or KME Light/ KMC file: FILE REPEAT, REPEAT OFF 	✓	✓	✓*3
Random play	<p>Press 3 ↻ repeatedly.</p> <ul style="list-style-type: none"> Audio CD: DISC RANDOM, RANDOM OFF AAC/MP3/WMA/iPod or KME Light/ KMC file: FOLDER/ FOLD RANDOM, RANDOM OFF <p>Press and hold 3 ↻ to select "ALL RANDOM."</p>	✓	✓	✓*3
		✓*2	✓	✓*3

*2 Only for AAC/MP3/WMA files.

*3 Applicable only when **[MODE OFF]** is selected.

*4 Only for files registered in the database created with KME Light/ KMC. (→ 9)

*5 Only for iPod.

Select a song by name (for **KDC-4757SD**)

While listening to iPod...

- 1 Press **Q**.
 - 2 Turn the volume knob to select a category, then press the knob.
 - 3 Press **Q** again.
 - 4 Turn the volume knob to select the character to be searched for.
 - 5 Press **◀▶** to move to the entry position. You can enter up to three characters.
 - 6 Press the volume knob to start searching.
 - 7 Turn the volume knob to make a selection, then press the knob.
Repeat step 7 until the desired item is selected.
- To search for a character other than A to Z and 0 to 9, enter only "**".
 - To return to the previous hierarchy, press **↶**.
 - To return to the top menu, press number button **5**.
 - To cancel, press and hold **↶**.

Set the skip ratio

While listening to iPod (for **KDC-4757SD**) or KME Light/ KMC file...

- 1 Press the volume knob to enter **[FUNCTION]**.
- 2 Turn the volume knob to select **[SETTINGS]**, then press the knob.
- 3 Turn the volume knob to select **[SKIP SEARCH]**, then press the knob.
- 4 Turn the volume knob to make a selection, then press the knob.
0.5% (default)/ **1%**/ **5%**/ **10%**: Sets the skip ratio when searching for a song.
(Holding **◀▶** skips songs at 10% regardless of the setting made.)
- 5 Press and hold **↶** to exit.

Muting upon the reception of a phone call

Connect the MUTE wire to your telephone using a commercial telephone accessory. (→ 13)

When a call comes in, "CALL" appears.

- The audio system pauses.
- To continue listening to the audio system during a call, press **⏻ SRC**. "CALL" disappears and the audio system resumes.

When the call ends, "CALL" disappears.

- The audio system resumes.

Preparation:

Select **[ON]** for **[BUILT-IN AUX]/ [BUILTIN AUX]**. (→ 4)

Start listening

- 1 Connect a portable audio player (commercially available).

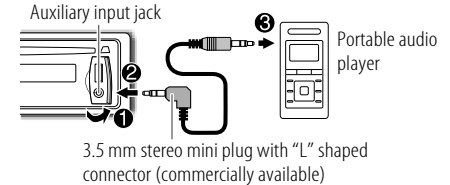

- 2 Press **⏻ SRC** to select AUX.
- 3 Turn on the portable audio player and start playback.

Set the AUX name

While listening to AUX...

- 1 Press the volume knob to enter **[FUNCTION]**.
- 2 Turn the volume knob to select **[SETTINGS]**, then press the knob.
- 3 Turn the volume knob to select **[AUX NAME SET]/ [AUX NAME]**, then press the knob.
- 4 Turn the volume knob to make a selection, then press the knob.
AUX (default)/ **DVD/ PORTABLE/ GAME/ VIDEO/ TV**
- 5 Press and hold **↶** to exit.

AUDIO SETTINGS

While listening to any source...

- 1 Press the volume knob to enter [FUNCTION].
 - 2 Turn the volume knob to select [AUDIO CONTROL]/ [AUDIO CTRL], then press the knob.
 - 3 Turn the volume knob to make a selection (see the following table), then press the knob.
Repeat step 3 until the desired item is selected or activated.
 - 4 Press and hold ↵ to exit.
- To return to the previous hierarchy, press ↶.

Default: **XX**

SUB-W LEVEL	-15 to +15 (0) : Adjusts the subwoofer output level.
BASS LEVEL	-8 to +8 (0) : Adjusts the level to memorize for each source. (Before making an adjustment, select the source you want to adjust.)
MID LEVEL	-8 to +8 (0) : Adjusts the level to memorize for each source. (Before making an adjustment, select the source you want to adjust.)
TRE LEVEL	-8 to +8 (0) : Adjusts the level to memorize for each source. (Before making an adjustment, select the source you want to adjust.)

EQ PRO	
BASS ADJUST	BASS CTR FRQ/ BASS C FRQ 60/ 80/ 100/ 200 : Selects the center frequency.
	BASS LEVEL -8 to +8 (0) : Adjusts the level.
	BASS Q FACTOR/ BASS Q FCTR 1.00/ 1.25/ 1.50/ 2.00 : Adjusts the quality factor.
MID ADJUST	BASS EXTEND ON : Turns on the extended bass. ; OFF : Cancels.
	MID CTR FRQ/ MID C FRQ 0.5K/ 1.0K/ 1.5K/ 2.5K : Selects the center frequency.
	MID LEVEL -8 to +8 (0) : Adjusts the level.
TRE ADJUST	MID Q FACTOR/ MID Q FCTR 0.75/ 1.00/ 1.25 : Adjusts the quality factor.
	TRE CTR FRQ/ TRE C FRQ 10.0K/ 12.5K/ 15.0K/ 17.5K : Selects the center frequency.
	TRE LEVEL -8 to +8 (0) : Adjusts the level.

PRESET EQ **NATURAL/ USER/ ROCK/ POPS/ EASY/ TOP40/ JAZZ/ POWERFUL**: Selects a preset equalizer suitable to the music genre. (Select [USER] to use the customized bass, middle, and treble settings.)

BASS BOOST	B. BOOST LV1/ B. BOOST LV2/ B. BOOST LV3 : Selects your preferred bass boost level. ; OFF : Cancels.
LOUDNESS	LOUDNESS LV1/ LOUD LV1/ LOUDNESS LV2/ LOUD LV2 : Selects your preferred low and high frequencies boost to produce a well-balanced sound at a low volume level. ; OFF : Cancels.
BALANCE	L15 to R15 (0) : Adjusts the left and right speaker output balance.
FADER	R15 to F15 (0) : Adjusts the rear and front speaker output balance.
SUBWOOFER SET/ SUB-W SET	ON : Turns on the subwoofer output. ; OFF : Cancels.

DETAILED SET/ DETAIL SET

HPF	For KDC-4757SD : THROUGH : All signals are sent to the speakers. ; 100HZ/ 120HZ/ 150HZ : Audio signals with frequencies higher than 100 Hz/ 120 Hz/ 150 Hz are sent to the speakers.
LPF SUBWOOFER/ LPF SUB-W	THROUGH : All signals are sent to the subwoofer. ; 85HZ/ 120HZ/ 160HZ : Audio signals with frequencies lower than 85 Hz/ 120 Hz/ 160 Hz are sent to the subwoofer.
SUB-W PHASE	REVERSE/ REV (180°)/ NORMAL/ NORM (0°) : Selects the phase of the subwoofer output to be in line with the speaker output for optimum performance. (Selectable only if a setting other than [THROUGH] is selected for [LPF SUBWOOFER]/ [LPF SUB-W].)
SUPREME SET	ON : Creates realistic sound by interpolating the high-frequency components that are lost in AAC/MP3/WMA audio compression. ; OFF : Cancels. (Selectable only when playing back an AAC/MP3/WMA disc, a USB device or an SD card, except iPhone/iPod.)
VOLUME OFFSET/ VOL OFFSET (Default: 0)	-8 to +8 (for AUX) ; -8 to 0 (for other sources): Presets the volume adjustment level of each source. (Before adjustment, select the source you want to adjust.)

- [SUB-W LEVEL]/ [SUBWOOFER SET]/ [SUB-W SET]/ [LPF SUBWOOFER]/ [LPF SUB-W]/ [SUB-W PHASE] is selectable only if [SWITCH PRE] is set to [SUB-W]. (→ 4)
- [SUB-W LEVEL]/ [LPF SUBWOOFER]/ [LPF SUB-W]/ [SUB-W PHASE] is selectable only if [SUBWOOFER SET]/ [SUB-W SET] is set to [ON].

DISPLAY SETTINGS

- 1 Press the volume knob to enter [FUNCTION].
 - 2 Turn the volume knob to select [SETTINGS], then press the knob.
 - 3 Turn the volume knob to make a selection (see the table below), then press the knob.
Repeat step 3 until the desired item is selected or activated.
 - 4 Press and hold **↵** to exit.
- To return to the previous hierarchy, press **↵**.

Default: **XX**

DISP & KEY (for **KDC-4757SD**)

COLOR SELECT **VARIABLE SCAN/ COLOR 01** — **COLOR 24/ USER**: Selects your preferred key illumination color.

You can create your own color (when [COLOR 01] — [COLOR 24] or [USER] is selected). The color you have created can be selected when you select [USER].

- 1 Press and hold the volume knob to enter the detailed color adjustment.
- 2 Press **◀◀ / ▶▶** to select the color (**R/ G/ B**) to adjust.
- 3 Turn the volume knob to adjust the level (**0** — **9**), then press the knob.

DISP DIMMER **ON**: Dims the display illumination. ; **OFF**: Cancels.

TEXT SCROLL **AUTO/ ONCE**: Selects whether to scroll the display information automatically, or scroll only once. ; **OFF**: Cancels.

KEY DIMMER **DIMMER LV1**: Dims the key illumination. ; **DIMMER LV2**: Dims the key illumination darker than **DIMMER LV1**. ; **DIMMER OFF**: Cancels.

DISPLAY

DISP DIMMER **ON**: Dims the display illumination. ; **OFF**: Cancels.

TEXT SCROLL **AUTO/ ONCE**: Selects whether to scroll the display information automatically, or scroll only once. ; **OFF**: Cancels.

MORE INFORMATION

General

- This unit can only play the following CDs:



- Detailed information and notes about the playable audio files are stated in an online manual on the following site:
www.kenwood.com/cs/ce/audiofile/

Playable files

- Playable Audio file: AAC (.m4a), MP3 (.mp3), WMA (.wma)
- Playable disc media: CD-R/RW/ROM
- Playable disc file formats: ISO 9660 Level 1/2, Joliet, Romeo, Long file name.
- Playable USB device file system: FAT16, FAT32

Although the audio files are compiled with the standards listed above, playback maybe impossible depending on the types or conditions of media or device.

Unplayable discs

- Discs that are not round.
- Discs with coloring on the recording surface or discs that are dirty.
- Recordable/ReWritable discs that have not been finalized.
- 8 cm CD. Attempting to insert using an adapter may cause malfunction.

About USB devices

- This unit can play AAC/MP3/WMA files stored on a USB mass storage class device.
- You cannot connect a USB device via a USB hub and Multi Card Reader.
- Connecting a cable whose total length is longer than 5 m may result in abnormal playback.
- This unit cannot recognize a USB device whose rating is other than 5 V and exceeds 1 A.

About SD card

- This unit is capable of playback of SD/SDHC memory cards complying with the SD or SDHC standard: SD card (≤2 GB), SDHC card (≤32 GB)
- A special adapter is required to use a miniSD card, miniSDHC card, microSD card or microSDHC card.
- The MultiMedia Card (MMC) cannot be used.
- Data recorded in the SD audio format cannot be played back.

About iPod/iPhone

Made for

- iPod touch (1st, 2nd, 3rd, and 4th generation)
- iPod classic
- iPod with video
- iPod nano (1st, 2nd, 3rd, 4th, 5th, and 6th generation)
- iPhone, iPhone 3G, 3GS, 4, 4S
- For the latest compatible list and software versions of iPhone/iPod, see: www.kenwood.com/cs/ce/ipod
- If you start playback after connecting the iPod, the music that has been played by the iPod is played first. In this case, “RESUMING” is displayed without displaying a folder name, etc. Changing the browse item will display the correct title, etc.
- You cannot operate iPod if “KENWOOD” or “✓” is displayed on iPod.

About “KENWOOD Music Editor Light” and “KENWOOD Music Control”

- This unit supports the PC application “KENWOOD Music Editor Light” and Android™ application “KENWOOD Music Control.”
- When you use an audio file with database information added using the “KENWOOD Music Editor Light” or “KENWOOD Music Control,” you can search for a file by title, album or artist name using Music Search.
- “KENWOOD Music Editor Light” and “KENWOOD Music Control” are available from the following web site:
www.kenwood.com/cs/ce/

TROUBLESHOOTING

Symptom	Remedy
Sound cannot be heard.	<ul style="list-style-type: none"> Adjust the volume to the optimum level. Check the cords and connections.
“PROTECT” appears and no operations can be done.	Check to be sure the terminals of the speaker wires are insulated properly, then reset the unit. If this does not solve the problem, consult your nearest service center.
<ul style="list-style-type: none"> Sound cannot be heard. The unit does not turn on. Information shown on the display is incorrect. 	Clean the connectors. (→ 2)
The unit does not work at all.	Reset the unit. (→ 3)
<ul style="list-style-type: none"> Radio reception is poor. Static noise while listening to the radio. 	<ul style="list-style-type: none"> Connect the antenna firmly. Pull the antenna out all the way.
“NA FILE” appears.	Make sure the disc contains supported audio files. (→ 9)
“NO DISC” appears.	Insert a playable disc into the loading slot.
“TOC ERROR” appears.	Make sure the disc is clean and inserted properly.
“PLS EJECT” appears.	Reset the unit. If this does not solve the problem, consult your nearest service center.
Disc cannot be ejected.	Press and hold ▲ to forcibly eject the disc. Be careful not to drop the disc when it is ejected. If this does not solve the problem, reset the unit. (→ 3)
“READ ERROR” appears.	Copy the files and folders onto the USB device/SD card again. If this does not solve the problem, reset the USB device/SD card or use another USB device/SD card.
“NO DEVICE” appears.	<ul style="list-style-type: none"> Connect a USB device, and change the source to USB again. SD card is not inserted properly. Insert an SD card, and change the source to SD again.
“COPY PRO” appears.	A copy-protected file is played.
“NO MUSIC” appears.	Connect a USB device/SD card that contains playable audio files.

Symptom	Remedy
“NA DEVICE” appears.	<ul style="list-style-type: none"> Connect a supported USB device, and check the connections. Insert a supported SD card properly.
“USB ERROR” appears.	<ul style="list-style-type: none"> Remove the USB device, turn the unit off, then turn it on again. Try to connect another USB device.
“iPod ERROR” appears.	<ul style="list-style-type: none"> Reconnect the iPod. Reset the iPod.
Noise is generated.	Skip to another track or change the disc.
Tracks do not play back as you have intended them to play.	Playback order is determined when files are recorded.
“READING” keeps flashing.	Do not use too many hierarchical levels or folders.
Elapsed playing time is not correct.	This is caused by how the tracks are recorded.
The number of songs contained in the “SONGS” category of this unit is different from the iPod/iPhone.	Podcast files are not counted on this unit as this unit does not support the playback of podcast files.
Correct characters are not displayed (e.g. album name).	This unit can only display uppercase letters, numbers, and a limited number of symbols. Uppercase Cyrillic letters can also be displayed if [RUSSIAN SET] is set to [ON]. (→ 4)

SPECIFICATIONS

Tuner	FM	Frequency Range	87.5 MHz to 108 MHz (50 kHz space)
		Usable Sensitivity (S/N = 26 dB)	1.0 μ V/75 Ω
		Quieting Sensitivity (DIN S/N = 46 dB)	2.5 μ V/75 Ω
		Frequency Response (± 3 dB)	30 Hz to 15 kHz
		Signal-to-Noise Ratio (MONO)	63 dB
		Stereo Separation (1 kHz)	40 dB
	MW	Frequency Range	531 kHz to 1 611 kHz (9 kHz space)
		Usable Sensitivity (S/N = 20 dB)	36 μ V
	LW	Frequency Range	153 kHz to 279 kHz (9 kHz space)
Usable Sensitivity (S/N = 20 dB)		57 μ V	

CD player	Laser Diode	GaAlAs
	Digital Filter (D/A)	8 times over sampling
	D/A Converter	24 Bit
	Spindle Speed	500 rpm to 200 rpm (CLV)
	Wow & Flutter	Below measurable limit
	Frequency Response (± 1 dB)	20 Hz to 20 kHz
	Total Harmonic Distortion (1 kHz)	0.01 %
	Signal-to-Noise Ratio (1 kHz)	105 dB
	Dynamic Range	90 dB
	AAC Decode	AAC-LC “.m4a” files
	MP3 Decode	Compliant with MPEG-1/2 Audio Layer-3
	WMA Decode	Compliant with Windows Media Audio

USB	USB Standard	USB 1.1, USB 2.0 (Full speed)
	Maximum Supply Current	DC 5 V $\overline{\text{---}}$ 1 A
	File System	FAT16/ 32
	AAC Decode	AAC-LC “.m4a” files
	MP3 Decode	Compliant with MPEG-1/2 Audio Layer-3
	WMA Decode	Compliant with Windows Media Audio

SD	Compatible Physical Format	Version 2.00
	Maximum Memory Capacity	32 GB
	File System	FAT16/ 32
	AAC Decode	AAC-LC “.m4a” files
	MP3 Decode	Compliant with MPEG-1/2 Audio Layer-3
WMA Decode	Compliant with Windows Media Audio	

Audio	Maximum Output Power	50 W \times 4	
	Output Power (DIN 45324, +B = 14.4 V)	30 W \times 4	
	Speaker Impedance	4 Ω to 8 Ω	
	Tone Action	Bass	100 Hz ± 8 dB
		Middle	1 kHz ± 8 dB
		Treble	12.5 kHz ± 8 dB
Preout Level / Load (CD)	2 500 mV/10 k Ω		
Preout Impedance	\leq 600 Ω		

Auxiliary	Frequency Response (± 3 dB)	20 Hz to 20 kHz
	Input Maximum Voltage	1 200 mV
	Input Impedance	10 k Ω

General	Operating Voltage	14.4 V (11 V to 16 V allowable)
	Maximum Current Consumption	10 A
	Installation Size (W \times H \times D)	182 mm \times 53 mm \times 160 mm
Weight	1.3 kg	

Subject to change without notice.

⚠ Warning

- The unit can only be used with a 12 V DC power supply, negative ground.
- Disconnect the battery's negative terminal before wiring and mounting.
- Do not connect Battery wire (yellow) and Ignition wire (red) to the car chassis or Ground wire (black) to prevent a short circuit.
- Insulate unconnected wires with vinyl tape to prevent a short circuit.
- Be sure to ground this unit to the car's chassis again after installation.

⚠ Caution

- For safety's sake, leave wiring and mounting to professionals. Consult the car audio dealer.
- Install this unit in the console of your vehicle. Do not touch the metal parts of this unit during and shortly after use of the unit. Metal parts such as the heat sink and enclosure become hot.
- Do not connect the \ominus wires of speaker to the car chassis, Ground wire (black), or in parallel.
- Mount the unit with the angle of 30° or less.
- If your vehicle wiring harness does not have the ignition terminal, connect Ignition wire (red) to the terminal on the vehicle's fuse box which provides 12 V DC power supply and is turned on and off by the ignition key.
- After the unit is installed, check whether the brake lamps, blinkers, wipers, etc. on the car are working properly.
- If the fuse blows, first make sure the wires are not touching car's chassis, then replace the old fuse with one that has the same rating.

Basic procedure

- 1 Remove the key from the ignition switch, then disconnect the \ominus terminal of the car battery.
- 2 Connect the wires properly.
See Wiring connection. (→ 13)
- 3 Install the unit to your car.
See Installing the unit (in-dash mounting).
- 4 Connect the \ominus terminal of the car battery.
- 5 Reset the unit. (→ 3)

Installing the unit (in-dash mounting)

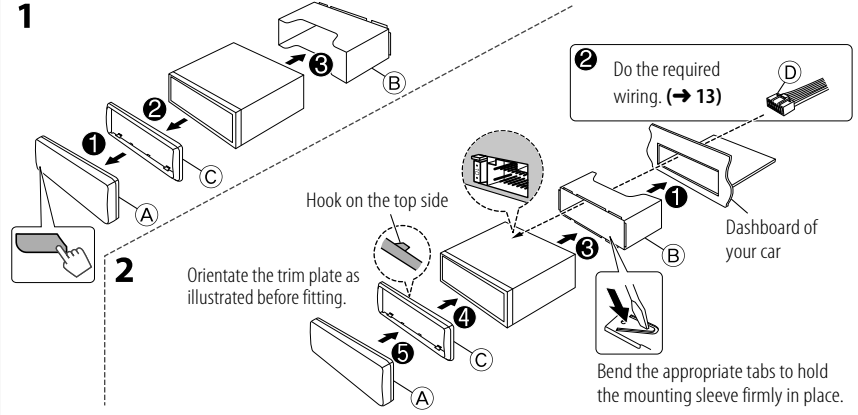

How to remove the unit

- 1 Detach the faceplate.
- 2 Fit the catch pin on the extraction keys into the holes on both sides of the trim plate, then pull it out.
- 3 Insert the extraction keys deeply into the slots on each side, then follow the arrows as shown on the right.

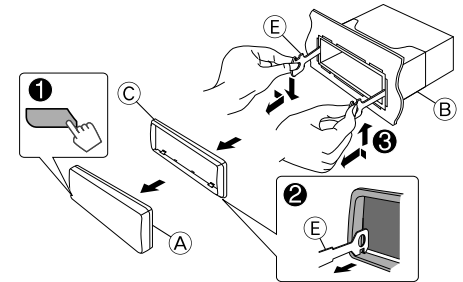

Wiring connection

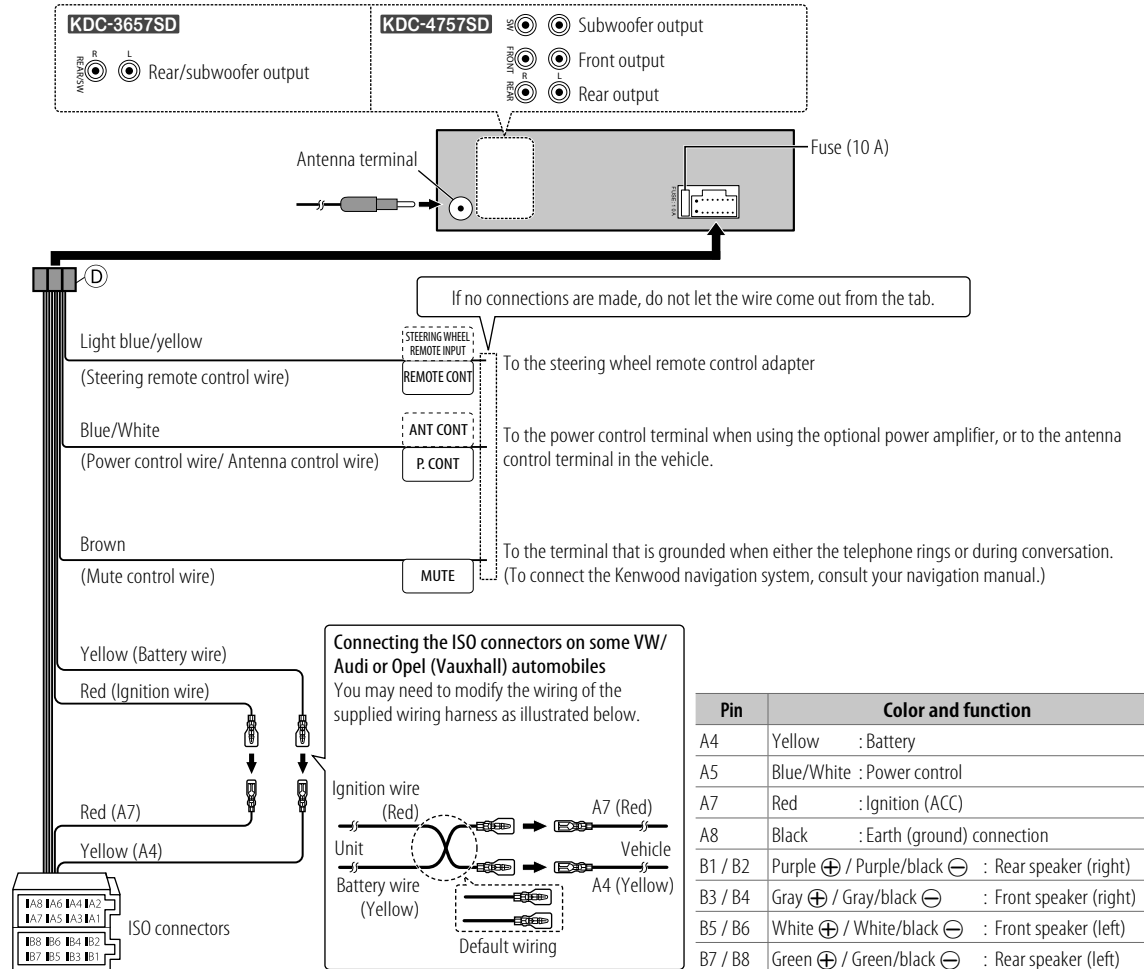

Part list for installation

- A Faceplate (×1)
- B Mounting sleeve (×1)
- C Trim plate (×1)
- D Wiring harness (×1)
- E Extraction key (×2)

Pin	Color and function
A4	Yellow : Battery
A5	Blue/White : Power control
A7	Red : Ignition (ACC)
A8	Black : Earth (ground) connection
B1 / B2	Purple ⊕ / Purple/black ⊖ : Rear speaker (right)
B3 / B4	Gray ⊕ / Gray/black ⊖ : Front speaker (right)
B5 / B6	White ⊕ / White/black ⊖ : Front speaker (left)
B7 / B8	Green ⊕ / Green/black ⊖ : Rear speaker (left)