

KENWOOD

KFC-W3000L KFC-W3000LS

ILLUMINATED SUBWOOFER

INSTRUCTION MANUAL

HAUT-PARLEUR DE GRAVES LUMINEUX

MODE D'EMPLOI

BELEUCHTETER SUBWOOFER

BEDIENUNGSANLEITUNG

SUBWOOFER MET VERLICHTING

GEBRUIKSAANWIJZING

SUBWOOFER ILLUMINATO

ISTRUZIONI PER L'USO

ALTAVOZ DE SUBGRAVES ILUMINADO

MANUAL DE INSTRUCCIONES

САБВУФЕР С ПОДСВЕТКОЙ

ИНСТРУКЦИЯ ПО ЭКСПЛУАТАЦИИ



AE86

Kenwood Corporation

© B61-1329-00/00 (W) KW

ENGLISH

FRANÇAIS

DEUTSCH

NEDERLANDS

ITALIANO

ESPAÑOL

РУССКИЙ

IMPORTANT SAFETY INSTRUCTIONS

⚠ Caution: Read this page carefully to ensure safe operation.

⚠ WARNING

- Before mounting or wiring etc., be sure to remove the wire from the battery minus terminal.
(Not doing so can cause shorts or fires.)
- To prevent a short circuit, never put or leave any metallic objects (such as coins or metal tools) inside the unit.
- In the event the unit generates smoke or abnormal smell, immediately switch the power OFF. After this, please contact your dealer or nearest service station as soon as possible.

POWER OFF!

- Connect the illumination lamp-equipped speakers to DC 12V, negative ground.
- Do not attempt to open or modify the unit, for this could cause fire hazard or malfunction.
- After taking the unit out of the polyethylene bag, be sure to dispose of the polyethylene bag out of the reach of children. Otherwise, they may play with the bag, which could cause hazard of suffocation.

⚠ CAUTION

- Installation and wiring of the product requires expert skill and experience. To ensure safety, be sure to have your dealer or specialist perform the installation and wiring.
- Do not install the speaker in a spot exposed to direct sunlight or excessive heat or humidity.
- Do not install the speakers in locations which may be subject to water or moisture.
- Do not install the speakers in unstable locations or locations subject to dust.
- If the fuse blows, after checking to see if the wiring cord has shorted, be sure to replace with the stipulated size (ampere) fuse as displayed on the fuse box.
(Using fuses other than the stipulated size can cause fires.)

Check the display!

To replace the fuse, refer to the vehicle instruction manual.

- To prevent a short circuit when replacing a fuse, disconnect the wiring harness at first.
- Do not use gasoline, naphtha, or any type of solvent to clean the speaker. Clean by wiping with a soft, dry cloth.
- Connect the speaker wires to appropriate speaker connectors separately. Sharing the negative wire of the speaker or grounding speaker wires to the metal body of the car can cause this unit to fail.
- When making a hole under a seat, inside the trunk, or somewhere else in the vehicle, check that there is nothing hazardous on the opposite side such as a gasoline tank, brake pipe; or wiring harness, and be careful not to cause scratches or other damage.
- For ground wire mounting, do not fasten the wire to an airbag, steering or brake line system or other critical safety unit bolts or nut.
(Can cause accidents.)
- When mounting, be sure to mount in a place that will not interfere with driving or be dangerous to passengers during sudden braking etc.
(Cause of injury or accidents.)
- After installing the unit, check to make sure that electrical equipment such as the brake lamps, turn signal lamps and windshield wipers operate normally.
- The driver should always stop the vehicle in a safe place before performing the following action.
 - Remote control operation
- Do not use the product for purposes other than on-board mounting.

Information on Disposal of Old Electrical and Electronic Equipment (applicable for EU countries that have adopted separate waste collection systems)



Products with the symbol (crossed-out wheeled bin) cannot be disposed as household waste. Old electrical and electronic equipment should be recycled at a facility capable of handling these items and their waste by products.

Contact your local authority for details in locating a recycle facility nearest to you. Proper recycling and waste disposal will help conserve resources whilst preventing detrimental effects on our health and the environment.



Declaration of Conformity with regard to the EMC Directive 2004/108/EC

Manufacturer:

Kenwood Corporation
2967-3 Ishikawa-machi, Hachioji-shi, Tokyo,
192-8525 Japan

EU Representative's:

Kenwood Electronics Europe BV
Amsterdamseweg 37, 1422 AC UITHOORN,
The Netherlands

FCC WARNING

This equipment may generate or use radio frequency energy. Changes or modifications to this equipment may cause harmful interference unless the modifications are expressly approved in the instruction manual. The user could lose the authority to operate this equipment if an unauthorized change or modification is made.

FCC NOTE



This equipment has been tested and found to comply with the limits for a Class B digital device, pursuant to Part 15 of the FCC Rules. These limits are designed to provide reasonable protection against harmful interference in a residential installation. This equipment may cause harmful interference to radio communications, if it is not installed and used in accordance with the instructions. However, there is no guarantee that interference will not occur in a particular installation. If this equipment does cause harmful interference to radio or television reception, which can be determined by turning the equipment off and on, the user is encouraged to try to correct the interference by one or more of the following measures:

- Reorient or relocate the receiving antenna.
- Increase the separation between the equipment and receiver.
- Connect the equipment into an outlet on a circuit different from that to which the receiver is connected.
- Consult the dealer or an experienced radio/TV technician for help.

For Canada

NOTICE: This Class B digital apparatus complies with Canadian ICES-003.

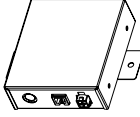
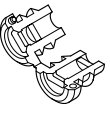
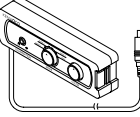
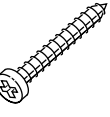
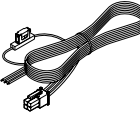
Parts included

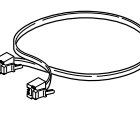
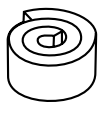
No.	Part Name	Outside Shape	Quantity		No.	Part Name	Outside Shape	Quantity	
			KFC-W3000L	KFC-W3000LS				KFC-W3000L	KFC-W3000LS
①	Control box		1	-	⑤	Cord bush		1	1
②	Remote control (Cord length: 6 m)		1	-	⑥	Screw ($\varnothing 4 \times 35$)		8	8
③	DC cable (Cable length: 1.5 m)		1	-	⑦	Screw ($\varnothing 4 \times 16$)		2	-
④	Link cable (Cable length: 1 m)		1	1	⑧	Cushion		1	1

Connection

⚠ Caution:

Before wiring, be sure to remove the wire from the negative terminal of the battery. After completing all wiring, check the correct wirings again. After checking, connect the wire from the negative terminal of the battery.

ENGLISH

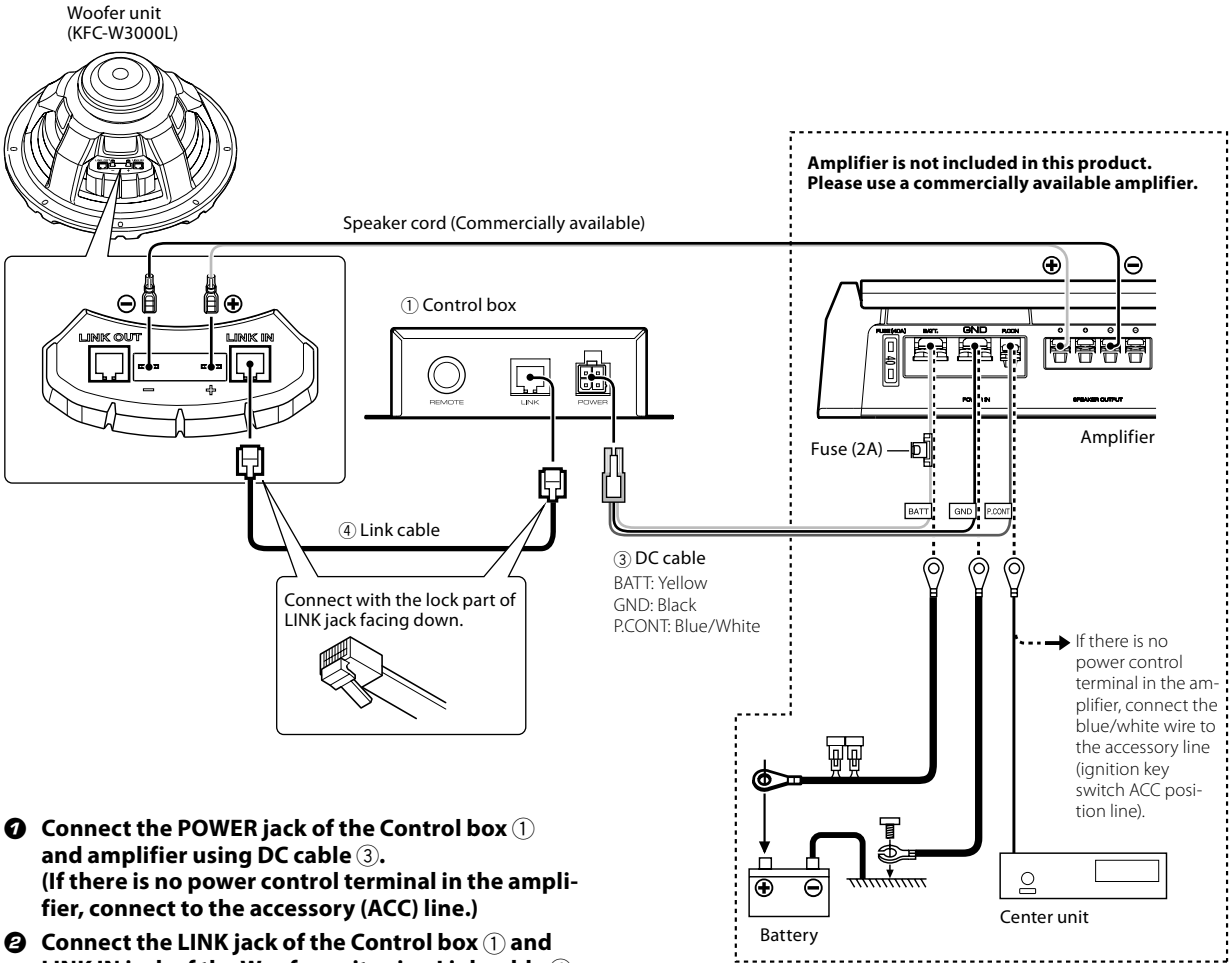

- ① Connect the POWER jack of the Control box ① and amplifier using DC cable ③. (If there is no power control terminal in the amplifier, connect to the accessory (ACC) line.)
- ② Connect the LINK jack of the Control box ① and LINK IN jack of the Woofer unit using Link cable ④. (A modular cable (commercially available) cannot be used.)
- ③ Connect the amplifier and the Woofer unit with speaker cords.

Notes:

- The illumination function cannot be used if the Link cable ④ is connected erroneously to the LINK OUT jack of the Woofer unit. Be sure to connect the Link cable ④ to the LINK IN jack.
- Do not plug or unplug the connection cables without switching the power off. Otherwise, malfunction may result.

Connecting the remote control unit

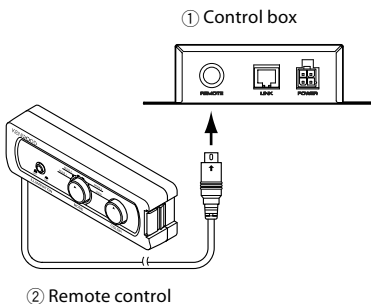

Connect the Remote control ② to the REMOTE terminal of the Control box ①.

Note:
The illumination function cannot be used when the Remote control ② is not connected. Be sure to connect the Remote control ② to the Control box ①.

Connecting KFC-W3000L and KFC-W3000LS (KFC-W3000LS user only)

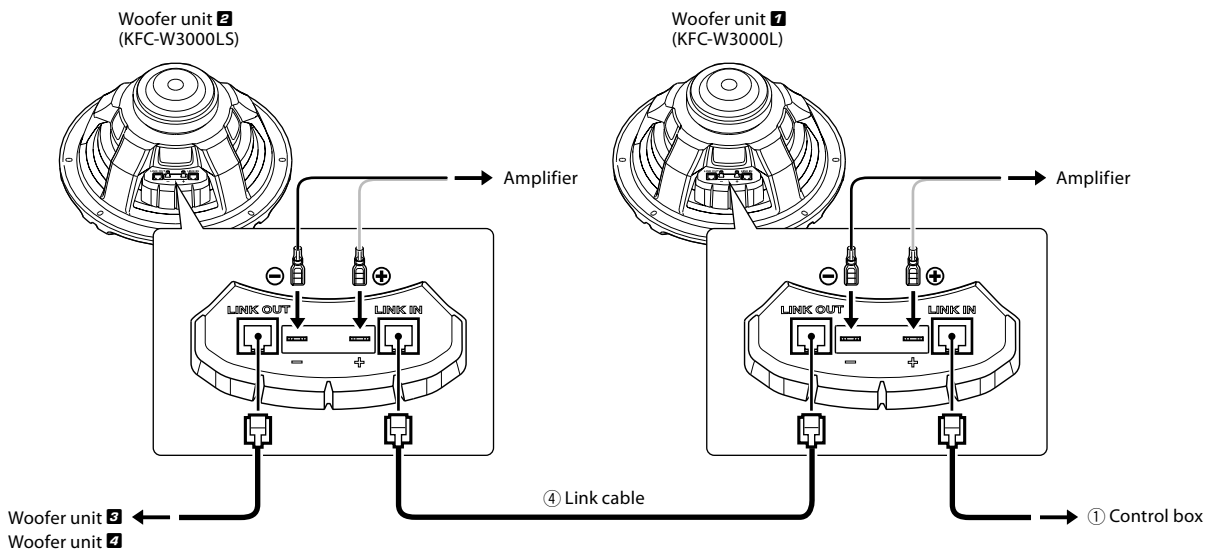

- ① Connect the LINK OUT jack of the Woofer unit 1 (KFC-W3000L) and LINK IN jack of the Woofer unit 2 (KFC-W3000LS) using Link cable ④.
- ② Connect the amplifier and the Woofer unit with speaker cords.

Notes:

- The illumination function of the KFC-W3000LS is enabled only when it is connected to the KFC-W3000L through the Link cable ④.
- The illumination function cannot be used when the KFC-W3000LS is not connected to the KFC-W3000L.
- The maximum number of connected KFC-W3000LS units is 3 (the maximum total number of Woofer units including the KFC-W3000L is 4).
- The illumination function cannot be used if the Link cable ④ is connected erroneously to the LINK OUT jack of the Woofer unit 2 (KFC-W3000LS). Be sure to connect the Link cable ④ to the LINK IN jack.
- The illumination is synchronized with the music signal input at the speaker terminal of the Woofer unit 1 (KFC-W3000L). The illuminations of the connected Woofer units 2, 3, 4 (KFC-W3000LS) light according to the Woofer unit 1 (KFC-W3000L). Note that they are not synchronized with the signals input to them.
- Do not plug or unplug the connection cables without switching the power off. Otherwise, malfunction may result.

Fuse exchange

Exchange with the specified capacity fuse.

Caution: Be sure to replace with same capacity (amperage) as displayed on the fuse. This product is 2A.

Removal

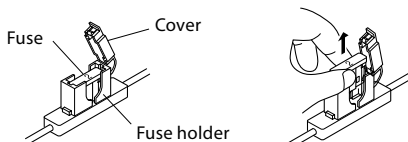

- ① Open the cover.
- ② Grasp with pliers and pull up.

Insertion

Replacement fuse 2A

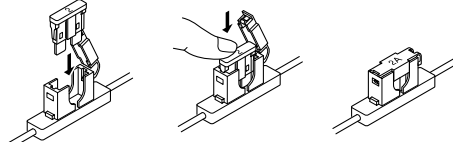

- ① Insert the fuse gently into the fuse holder and push in all the way with your finger or tool.
- ② Close the cover.

Installation

Fixing the Subwoofer

- ❶ Place the supplied template on the panel and then mark the hole positions.
- ❷ Cut open a large hole and make screw holes.
- ❸ Peel off the covering sheet from the spacer, and attach the spacer on the back of the speaker flange so that the flange is completely covered.

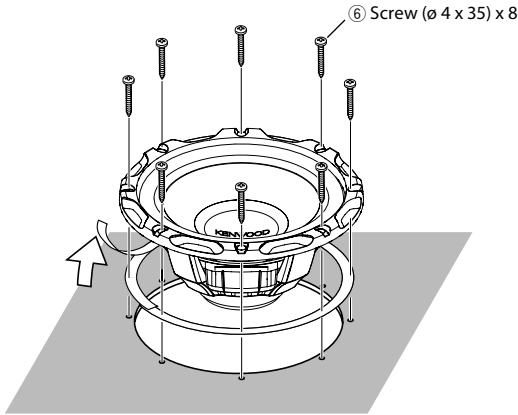

How to use the Cord bush

When you use a box for Woofer, use the attached Cord bush.

- ❶ On the Woofer box, make a hole (ø 17.5) for fitting the Cord bush ❺.
- ❷ Pass the Link cable ❹ through the hole on the Woofer box.
- ❸ Attach the Cord bush ❺ on an appropriate position of the Link cable ❹.
- ❹ Push the Cord bush ❺ into the hole on the Woofer box.

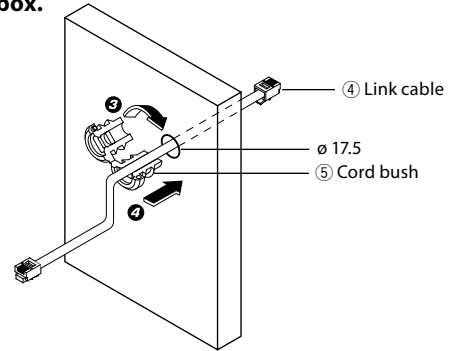

Notes:

- Fit the Cord bush ❺ firmly because clearance will lead to air leak.
- Be careful not to pinch the Link cable ❹ with the surface of the Cord bush ❺.

Fixing the Control box

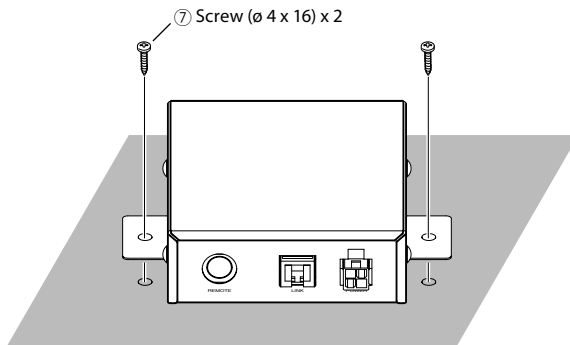

Technical specifications

	SYMBOL	UNIT	VALUE
Nominal impedance	Z	Ω	4
DC resistance	Revc	Ω	3.4
Voice coil inductance	Levc	mH	0.56
Piston area	Sd	sq.m	0.052
Force factor	BL	T.m	9.53
Volume acoustic compliance	Vas	Liters	97.75
		cu.ft	3.45
Moving mass	Mms	g	105.6
Resonance frequency	Fs	Hz	30.9
Mechanical Q factor	Qms		9.59
Electrical Q factor	Qes		0.77
Total Q factor	Qts		0.71
Peak power		W	800
Peak excursion	Xmax	mm	4.6
Displacement		cc	5,190
		cu.ft	0.183
Mounting depth		mm (in.)	150 (5-7/8)
Weight of magnet		g (oz)	740 (26.1)
Voice coil diameter		mm (in.)	50 (1-15/16)

Recommended enclosures

SEALED

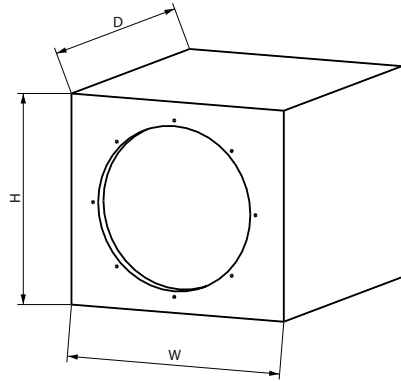
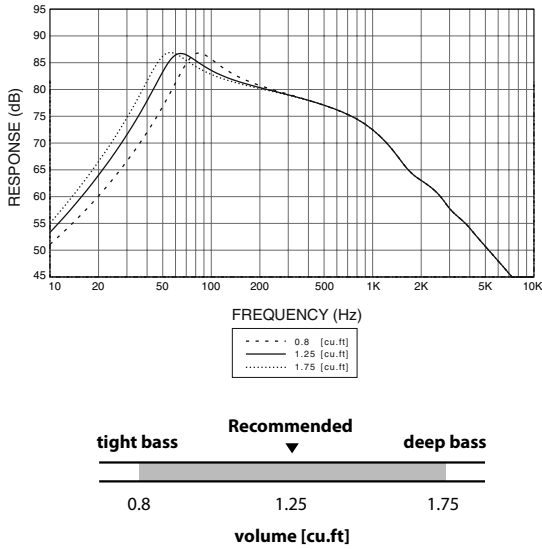

* W, H, D : External Dimensions

Type	Inner Volume	W	H	D	Mounting Hole	Displacement
SEALED	1.25 cft (35.4 Liter)	375 mm (14-3/4")	370 mm (14-9/16")	355 mm (14")	282 mm (11-1/8")	0.11 cu.ft

Use 19 mm (3/4 inch) thick Medium Density Fiberboard (MDF) or High Density Particleboard.

PORTED

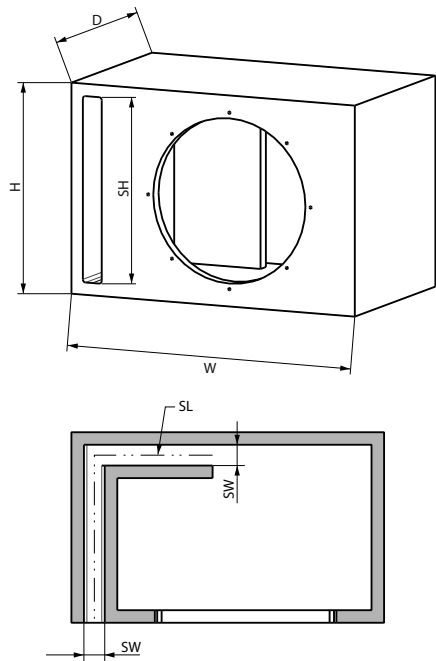
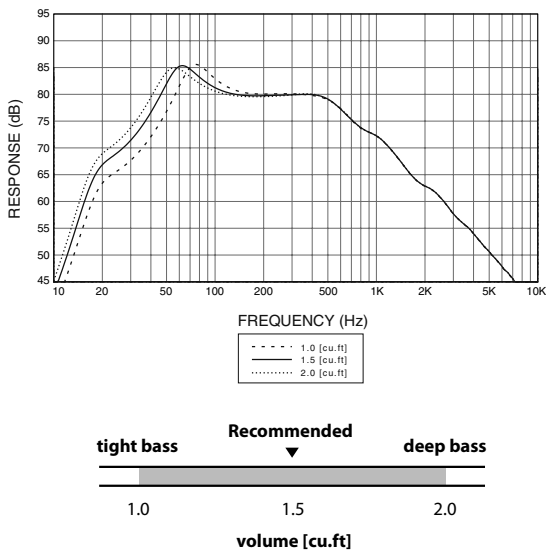

* W, H, D : External Dimensions

Type	Inner Volume	W	H	D	Mounting Hole	SW	SH	SL	Displacement
PORTED	1.5 cft (42.5 Liter)	507 mm (19-15/16")	360 mm (14-3/16")	320 mm (12-5/8")	282 mm (11-1/8")	35 mm (1-3/8")	322 mm (12-11/16")	480 mm (18-7/8")	0.11 cu.ft

Use 19 mm (3/4 inch) thick Medium Density Fiberboard (MDF) or High Density Particleboard.

ENGLISH

Operation

ILLUMINATION switch
Select whether or not the illumination is used.

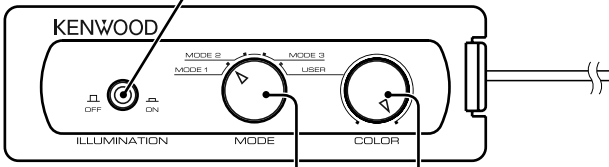

MODE selector
For each mode, refer to the table described below.

Color change volume
Used this knob in "USER" mode.
The color tone can be adjusted as desired.
Fully counterclockwise = White ←→ Red = Fully clockwise (Intermediate colors available)

Notes:

- It is discommended to light the illuminations when the vehicle is moving.
- Do not stare at the illumination light for a long period.
- The illumination function may malfunction if connections are erroneous. Be sure to connect the equipment properly by referring to "Connection" in this manual (on page 4, 5).

ENGLISH

Changing the illumination mode

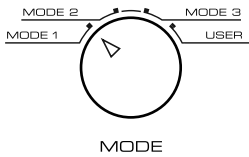

Turn the MODE selector knob to select the illumination mode. Each mode (MODE 1, 2, 3 or USER) changes depends on whether the music signal is existing or not.

On Music Mode The On Music Mode is entered when a music signal is detected.		Off Music Mode The Off Music Mode is entered when no music signal has been input for 20 seconds.	
MODE 1	Cycle mode Repeats MODE 2→MODE 3→USER→MODE 2... Each mode changes every 20 seconds.	MODE 1	Cycle mode Repeats MODE 2→MODE 3→USER→MODE 2... Each mode changes after it has been played twice.
MODE 2	Variable mode The illumination rotates along a circumference. Illumination color changes depends on the signal level. Signal level low = Deep blue ←→ Red = Signal level high You can adjust the illumination sensitivity with INPUT SENSITIVITY control knob.	MODE 2	Variable mode The illumination flows from the top to the bottom.
MODE 3	Sound Link mode The illumination lights in synchronism with music. Illumination color changes depends on the signal level. Signal level low = White ←→ Red = Signal level high You can adjust the illumination sensitivity with INPUT SENSITIVITY control knob.	MODE 3	Quiet mode White lights slowly.
USER	User mode The illumination lights in synchronism with music. You can change the illumination color with Color change volume. White ←→ Red (Intermediate colors available)	USER	User mode The selected color lights slowly. You can change the illumination color with Color change volume. White ←→ Red (Intermediate colors available)

Adjusting the illumination sensitivity

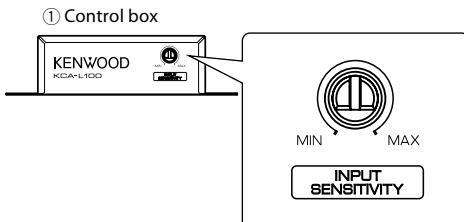

In the "On Music Mode", you can adjust the illumination sensitivity.

Turn the INPUT SENSITIVITY control knob using a minus driver to adjust the illumination sensitivity as desired.

Troubleshooting guide

Often, what appears to be a malfunction is due to user error. Before calling for service, please consult the following table.

Problem	Cause	Remedy
Illumination does not light.	• The fuse is blown.	• Check the (+)/(-) polarity of the power cord and that the cords are not shorted, then replace with a fuse with the rated capacity. • Re-connect the cords correctly by referring to the connection example (on page 4, 5).
	• The remote control cord is unplugged.	• Plug the cord into the REMOTE terminal.
	• The power supply pin (yellow) of the DC cable is not connected.	• Connect the cord correctly by referring to the connection example (on page 4, 5). • Check the connections of all cords, then connect the (-) cable to the battery. • Insert the connector all the way in.
	• The power control pin (blue/white) of the DC cable is not connected.	
	• The DC cable is not plugged in completely.	• Attach the grounding terminal to the metallic section of the vehicle (not a coated surface) by tightly screwing it.
	• The grounding pin (black) of the DC cable is not connected.	
	• The negative (-) cable of the car battery is disconnected.	• Check the connections of all cords, then connect the (-) cable to the battery.
	• The ON/OFF switch of the remote control unit is set to OFF.	• Switch the ON/OFF switch to ON.
• The Link cable is connected improperly.	• Connect the cords correctly by referring to the connection example (on page 4, 5). • Insert the connector all the way in.	
Illumination is not synchronized with the sound.	• No audio signal is input to the speaker.	• Connect the cords correctly by referring to the connection example (on page 4, 5).
	• Speaker's volume is low.	• Adjust with the INPUT SENSITIVITY control knob of the Control box clockwise (MAX side) (on page 8).
The illumination color does not change.	• Speaker's volume is high.	• Adjust with the INPUT SENSITIVITY control knob of the Control box counter-clockwise (MIN side) (on page 8).
	• The MODE selector is set to "USER".	• Turn the MODE selector to MODE 1, 2, or 3 (on page 8).
No sound	• The attenuator of the center unit is set to ON.	• Switch the attenuator OFF.
	• The speaker cords are connected improperly.	• Connect the cords correctly by referring to the connection example (on page 4, 5).
	• Connection terminals are connected improperly.	• Insert the connectors or jacks all the way in to the terminals.
Sound is small.	• The input level is set to low.	• Adjust the volume of the Center unit.
Sound quality is bad (sound is distorted).	• The input level is set to high.	
Sound is unnatural.	• The speaker cords are connected with incorrect positive (+)/negative (-) polarity.	• Connect the cords correctly by referring to the connection example (on page 4, 5).

ENGLISH

Specifications

The following ratings and design are subject to change without notice.

[Speaker unit]

Subwoofer 300 mm (12 in.) Injection PP Cone
 740 g (26.1 oz) Magnet
 Peak input power 800 W
 Maximum input power 400 W
 Rated input power 200 W
 Frequency response 28 - 800 Hz
 Sensitivity 90 dB / W at 1 m
 Rated impedance 4 Ω

[Control unit]

Operating voltage DC 14.4 V (10.5 ~ 16 V allowable)
 Maximum current consumption 150 mA
 Fuse capacity 2 A