

# KENWOOD

## INSTRUCTION MANUAL



VHF FM TRANSCEIVER

# TK-7185

### NOTIFICATION

This equipment complies with the essential requirements of Directive 1999/5/EC.

The use of the warning symbol ⓘ means the equipment is subject to restrictions of use in certain countries.

This equipment requires a licence and is intended for use in the countries as below.

AT	BE	DK	FI	FR	DE	GR	IS
IE	IT	LI	LU	NL	NO	PT	ES
SE	CH	GB	CY	CZ	EE	HU	LV
LT	MT	PL	SK	SI	BG	RO	

ISO3166

Kenwood Corporation

CE0168 ⓘ

© B62-2105-00 (E)  
09 08 07 06 05 04 03 02 01 00



## THANK YOU!

We are grateful you chose **Kenwood** for your personal mobile applications. We believe this easy-to-use transceiver will provide dependable communications to keep personnel operating at peak efficiency.

**Kenwood** transceivers incorporate the latest in advanced technology. As a result, we feel strongly that you will be pleased with the quality and features of this product.

## NOTICES TO THE USER

- ◆ Government law prohibits the operation of unlicensed transmitters within the territories under government control.
- ◆ Illegal operation is punishable by fine and/or imprisonment.
- ◆ Refer service to qualified technicians only.

**SAFETY:** It is important that the operator is aware of, and understands, hazards common to the operation of any transceiver.



- ◆ **EXPLOSIVE ATMOSPHERES (GASES, DUST, FUMES, etc.)**  
Turn OFF your transceiver while taking on fuel or while parked in gasoline service stations. Do not carry spare fuel containers in the trunk of your vehicle if your transceiver is mounted in the trunk area.
- ◆ **INJURY FROM RADIO FREQUENCY TRANSMISSIONS**  
Do not operate your transceiver when somebody is either standing near to or touching the antenna, to avoid the possibility of radio frequency burns or related physical injury.
- ◆ **DYNAMITE BLASTING CAPS**  
Operating the transceiver within 500 feet (150 m) of dynamite blasting caps may cause them to explode. Turn OFF your transceiver when in an area where blasting is in progress, or where "TURN OFF TWO-WAY RADIO" signs have been posted. If you are transporting blasting caps in your vehicle, make sure they are carried in a closed metal box with a padded interior. Do not transmit while the caps are being placed into or removed from the container.

### Information on Disposal of Old Electrical and Electronic Equipment and Batteries (applicable for EU countries that have adopted separate waste collection systems)

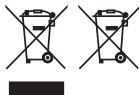

Products and batteries with the symbol (crossed-out wheeled bin) cannot be disposed as household waste.

Old electrical and electronic equipment and batteries should be recycled at a facility capable of handling these items and their waste byproducts.

Contact your local authority for details in locating a recycle facility nearest to you.

Proper recycling and waste disposal will help conserve resources whilst preventing detrimental effects on our health and the environment.

## PRECAUTIONS

Observe the following precautions to prevent fire, personal injury, and transceiver damage.

- Do not attempt to configure the transceiver while driving; it is too dangerous.
- Do not disassemble or modify the transceiver for any reason.
- Do not expose the transceiver to long periods of direct sunlight, nor place it near heating appliances.
- If an abnormal odor or smoke is detected coming from the transceiver, switch the transceiver power off immediately, and contact your **Kenwood** dealer.
- Use of the transceiver while you are driving may be against traffic laws. Please check and observe the vehicle regulations in your area.
- Do not use options not specified by **Kenwood**.



### CAUTION

- ◆ The transceiver operates in 12 V negative ground systems only! Check the battery polarity and voltage of the vehicle before installing the transceiver.
- ◆ Use only the supplied DC power cable or a **Kenwood** optional DC power cable.
- ◆ Do not cut and/or remove the fuse holder on the DC power cable.



### WARNING

For passenger safety, install the transceiver securely using the supplied mounting bracket and screw set so the transceiver will not break loose in the event of a collision.

# CONTENTS

<b>UNPACKING AND CHECKING EQUIPMENT .....</b>	<b>1</b>
<b>SUPPLIED ACCESSORIES .....</b>	<b>1</b>
<b>PREPARATION .....</b>	<b>2</b>
<b>TOOLS REQUIRED .....</b>	<b>2</b>
<b>POWER CABLE CONNECTION .....</b>	<b>2</b>
<b>INSTALLING THE TRANSCEIVER .....</b>	<b>3</b>
<b>GETTING ACQUAINTED.....</b>	<b>4</b>
<b>FRONT PANEL.....</b>	<b>4</b>
<b>REAR PANEL .....</b>	<b>5</b>
<b>BASIC OPERATIONS.....</b>	<b>6</b>
<b>SWITCHING POWER ON/ OFF .....</b>	<b>6</b>
<b>ADJUSTING THE VOLUME.....</b>	<b>6</b>
<b>TRUNKING MODE.....</b>	<b>7</b>
<b>KEY FUNCTIONS .....</b>	<b>7</b>
<b>DISPLAY.....</b>	<b>8</b>
<b>PROGRAMMABLE FUNCTIONS .....</b>	<b>9</b>
<b>SEARCHING FOR A CONTROL CHANNEL .....</b>	<b>9</b>
<b>VOICE CALLS.....</b>	<b>10</b>
<b>STATUS CALLS .....</b>	<b>11</b>
<b>DATA CALLS .....</b>	<b>11</b>
<b>CALL DISPLAYS.....</b>	<b>12</b>
<b>VIEWING THE STACK .....</b>	<b>12</b>
<b>CALL DIVERTING .....</b>	<b>13</b>
<b>KEYPAD ENTRY.....</b>	<b>14</b>
<b>EMERGENCY CALLS .....</b>	<b>14</b>
<b>PUBLIC ADDRESS (PA).....</b>	<b>14</b>
<b>HORN ALERT .....</b>	<b>14</b>
<b>AUXILIARY PORT .....</b>	<b>15</b>
<b>GPS REPORT.....</b>	<b>15</b>
<b>HOME ADDRESS.....</b>	<b>15</b>
<b>SITE LOCK .....</b>	<b>15</b>
<b>SUB-LCD DISPLAY .....</b>	<b>15</b>
<b>SWITCHING TO CONVENTIONAL MODE .....</b>	<b>15</b>

<b>CONVENTIONAL MODE</b> .....	<b>16</b>
<b>KEY FUNCTIONS</b> .....	<b>16</b>
<b>DISPLAY</b> .....	<b>17</b>
<b>PROGRAMMABLE FUNCTIONS</b> .....	<b>18</b>
<b>CONVENTIONAL OPERATION</b> .....	<b>18</b>
<b>SCANNING</b> .....	<b>18</b>
<b>SQUELCH OFF</b> .....	<b>19</b>
<b>EMERGENCY (TRUNKING)</b> .....	<b>19</b>
<b>QUIET TALK (QT)/ DIGITAL QUIET TALK (DQT)</b> .....	<b>19</b>
<b>TIME-OUT TIMER (TOT)</b> .....	<b>20</b>
<b>BUSY CHANNEL LOCKOUT (BCL)</b> .....	<b>20</b>
<b>SWITCHING TO TRUNKING MODE</b> .....	<b>20</b>
<b>ADVANCED &amp; BACKGROUND OPERATIONS</b> .....	<b>21</b>
<b>SCRAMBLER</b> .....	<b>21</b>
<b>DTMF (DUAL TONE MULTI FREQUENCY) CALLS</b> .....	<b>21</b>
<b>GPS POSITION DISPLAY</b> .....	<b>21</b>
<b>LCD BRIGHTNESS</b> .....	<b>21</b>
<b>CLOCK</b> .....	<b>22</b>
<b>SIGNAL STRENGTH INDICATOR</b> .....	<b>22</b>
<b>VGS-1 OPTIONAL VOICE GUIDE &amp; STORAGE UNIT</b> .....	<b>23</b>
<b>VOICE RECORDER</b> .....	<b>23</b>
<b>VOICE GUIDE</b> .....	<b>24</b>
<b>APPENDIX</b> .....	<b>25</b>

# UNPACKING AND CHECKING EQUIPMENT

**Note:** The following unpacking instructions are for use by your **Kenwood** dealer, an authorized **Kenwood** service facility, or the factory.

Carefully unpack the transceiver. We recommend that you identify the items listed in the following table before discarding the packing material. If any items are missing or have been damaged during shipment, file a claim with the carrier immediately.

## SUPPLIED ACCESSORIES

Item	Part Number	Quantity
DC power cable	E30-7523-XX	1
• Fuse (15 A)	F52-0024-XX	2
Mounting bracket	J29-0726-XX	1
Screw set	N99-2039-XX	1
• Self-tapping screw (4 pieces)		
• Hex-headed screw with washer (4 pieces)		
• Spring washer (4 pieces)		
• Flat washer (4 pieces)		
Instruction manual	B62-2105-XX	1

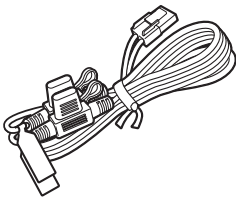

DC power cable  
(with fuses)

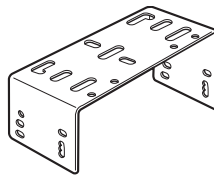

Mounting bracket

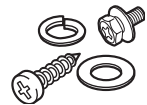

Screw set

# PREPARATION



## WARNING

Various electronic equipment in your vehicle may malfunction if they are not properly protected from the radio frequency energy which is present while transmitting. Electronic fuel injection, anti-skid braking, and cruise control systems are typical examples of equipment that may malfunction. If your vehicle contains such equipment, consult the dealer for the make of vehicle and enlist his/her aid in determining if they will perform normally while transmitting.

**Note:** The following preparation instructions are for use by your **Kenwood** dealer, an authorized **Kenwood** service facility, or the factory.

## TOOLS REQUIRED

**Note:** Before installing the transceiver, always check how far the mounting screws will extend below the mounting surface. When drilling mounting holes, be careful not to damage vehicle wiring or parts.

The following tools are required for installing the transceiver:

- 1/4 inch (6 mm) or larger electric drill
- 5/32 inch (4.2 mm) drill bit for the self-tapping screws
- Circle cutters

## POWER CABLE CONNECTION



## CAUTION

- ◆ The transceiver operates in **12 V** negative ground systems only! Check the battery polarity and voltage of the vehicle before installing the transceiver.
- ◆ Do not cut and/or remove the fuse holder on the DC power cable.

- 1 Check for an existing hole, conveniently located in the firewall, where the power cable can be passed through. If no hole exists, use a circle cutter to drill the firewall, then install a rubber grommet.
- 2 Run the two power cable leads through the firewall and into the engine compartment, from the passenger compartment.
- 3 Connect the red lead to the positive (+) battery terminal and the black lead to the negative (-) battery terminal.
  - Locate the fuse as close to the battery as possible.
- 4 Coil and secure the surplus cable with a retaining band.
  - Be sure to leave enough slack in the cables so the transceiver can be removed for servicing while keeping the power applied.



## INSTALLING THE TRANSCEIVER



### WARNING

For passenger safety, install the transceiver securely using the supplied mounting bracket and screw set so the transceiver will not break loose in the event of a collision.

- 1 Mark the position of the holes in the dash by using the mounting bracket as a template. Drill the holes, then attach the mounting bracket using the supplied self-tapping screws.
  - Be sure to mount the transceiver in a location where the controls are within easy reach of the user and where there is sufficient space at the rear of the transceiver for cable connections.
- 2 Connect the antenna and the supplied power cable to the transceiver.
- 3 Slide the transceiver into the mounting bracket and secure it using the supplied hex-headed screws.
- 4 Mount the optional microphone hanger in a location where it will be within easy reach of the user.
  - The optional microphone and microphone cable should be mounted in a place where they will not interfere with the safe operation of the vehicle.



### CAUTION

When replacing the fuse in the DC power cable, be sure to replace it with a fuse of the same value. Never replace a fuse with a fuse that has a higher value.

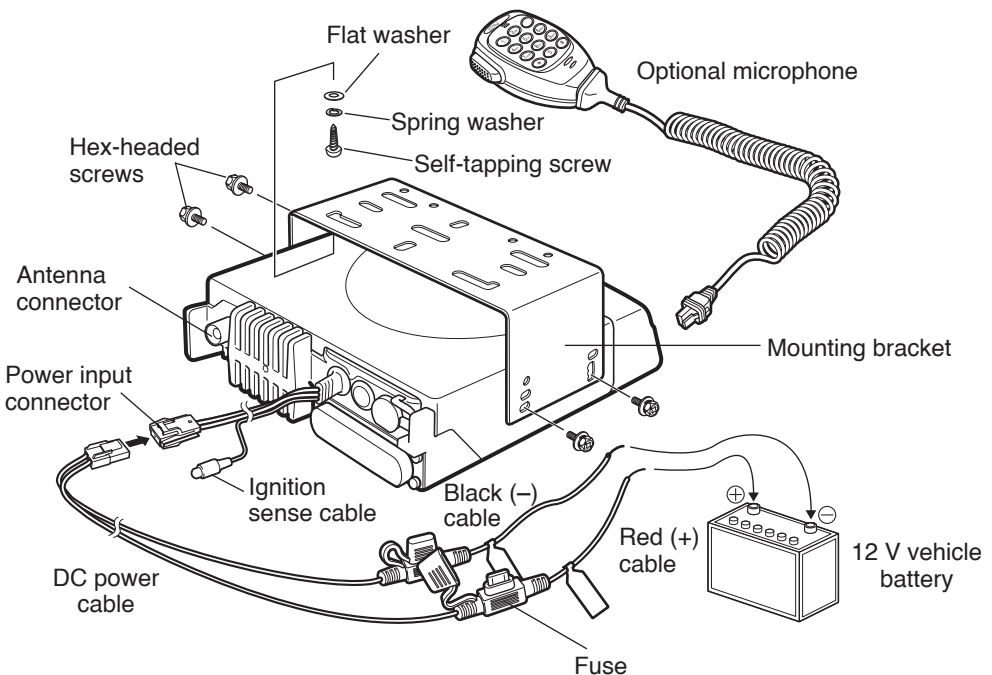

# GETTING ACQUAINTED

## FRONT PANEL

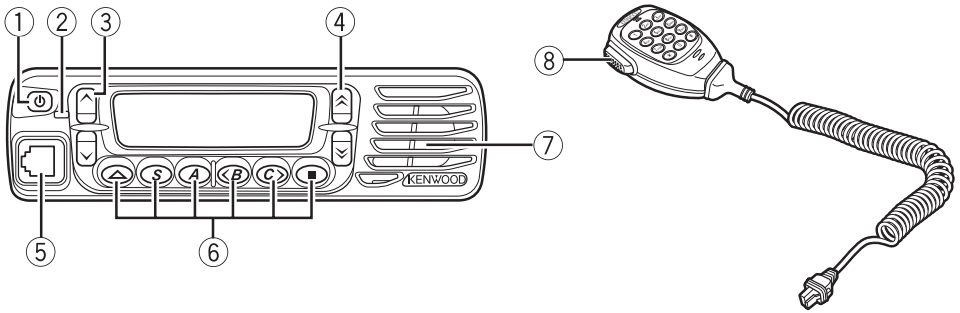

- ① **⏻ (Power) switch**  
Press to switch the transceiver ON. Press again to switch the transceiver OFF.
- ② **Transmit/ Busy indicator**  
This LED lights red while transmitting and green while receiving a call.
- ③ **^ / v keys**  
Press the ^ / v keys to adjust the volume level. ^ increases the volume and v decreases it.
- ④ **⤴ / ⤵ keys**  
Press the ⤴ / ⤵ keys to select your desired channel/ call address (voice calls) or status (status calls).
- ⑤ **Microphone jack**  
Insert the microphone plug into this jack.
- ⑥ **△, S, A, <B, C>, and ■ keys**  
Press to activate their programmable functions\*.
- ⑦ **Speaker**  
Internal speaker.
- ⑧ **PTT (Push-to-Talk) switch**  
Press and hold this switch, then speak into the microphone to call a station.

\* Programmable functions vary, depending on the transceiver operating mode. Refer to Trunking Mode {page 7} or Conventional Mode {page 16} for applicable functions.

# REAR PANEL

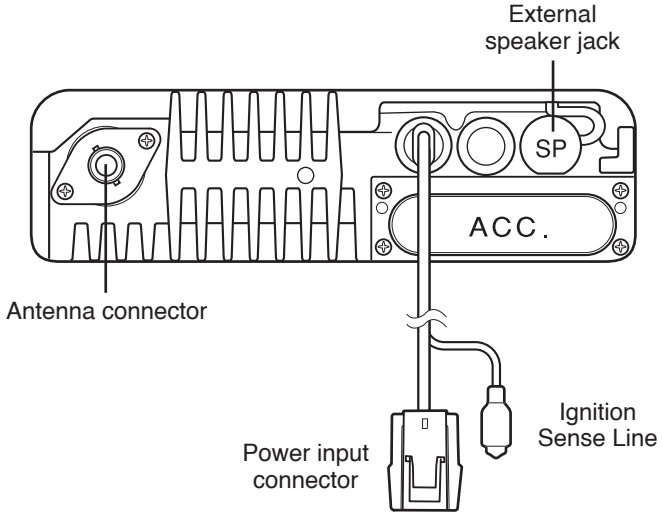

# BASIC OPERATIONS

## SWITCHING POWER ON/ OFF

Press the **⏻** switch to switch the transceiver ON.

- A beep sounds and the display momentarily lights up.
- If the Transceiver Password function is programmed, "PASSWORD" appears on the display. If a key has been programmed as **Transceiver Password**, you must press this key first, before "PASSWORD" appears on the display. You must enter the password to unlock the transceiver. Refer to "Transceiver Password", below.

Press the **⏻** switch again to switch the transceiver OFF.

- If set up by your dealer, the transceiver will switch ON and OFF with the vehicle ignition.

## ■ TRANSCEIVER PASSWORD

To enter the transceiver password:

- 1 Press the microphone DTMF keys corresponding to the password digits.
  - Alternatively, you can enter the password by pressing the **⤴** and **⤵** keys to select a digit, followed by pressing the **C>** key to accept the entered digit and move to the next digit.
  - Press the **A** or microphone **#** key to delete an incorrect character. Press and hold the **A** or microphone **#** key to delete all entered characters.
- 2 Press the **S** or microphone **\*** key to confirm the password.
  - If you enter an incorrect password, an error tone sounds and the transceiver remains locked.

## ADJUSTING THE VOLUME

Press the **⤴** key to increase the volume and the **⤵** key to decrease the volume.

When increasing or decreasing the volume level, the Volume Level indicator appears on the display. The transceiver volume level can be adjusted between levels 0 and 31.

# TRUNKING MODE

## KEY FUNCTIONS

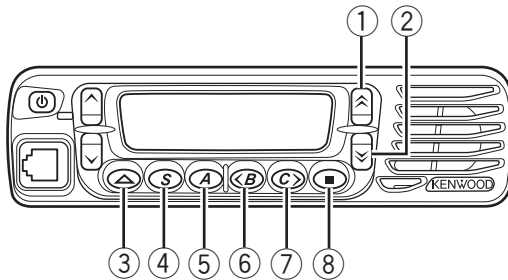

- ① **↑ key**  
Press to increase the Call Address or Status Call.
- ② **↓ key**  
Press to decrease the Call Address or Status Call.
- ③ **← key**  
Press to activate its programmable function {page 9}.  
The default setting is Call.
- ④ **S key**  
Press to activate its programmable function {page 9}.  
The default setting is Status/ Stack.
- ⑤ **A key**  
Press to activate its programmable function {page 9}.  
The default setting is Redial.
- ⑥ **<B key**  
Press to activate its programmable function {page 9}.  
The default setting is LCD Brightness.
- ⑦ **C> key**  
Press to activate its programmable function {page 9}.  
The default setting is Clock.
- ⑧ **■ key**  
Press to activate its programmable function {page 9}.  
The default setting is Clear.

## DISPLAY

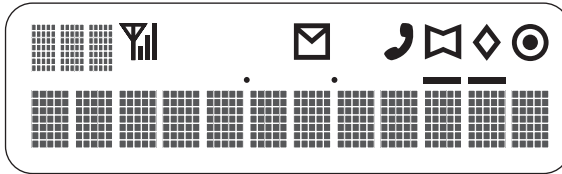

Indicator	Description
	Displays call addresses, received messages, and transceiver status messages.
	Displays received call types, transceiver functions, status numbers, and output power.
	Displays the strength of received signals. An antenna and all 3 strength bars represents strong signals while the antenna by itself (no strength bars) represents weak signals.
	Flashes when you receive a message. Lights when a message is stored in the queue memory.
	Appears when call diversions on your transceiver have been set up.
	Appears when the Horn Alert function is activated.
	Appears when the Scrambler function is activated.
	Appears when the Public Address function is activated.
	Appears when the Auto Recording function on the VGS-1 option is activated.
	Appears when an Auto Reply Message on the VGS-1 option is activated.
	Appears when the AUX A function has been activated.
	Appears when the AUX B function has been activated.

## PROGRAMMABLE FUNCTIONS

The  $\triangle$ , **S**, **A**, **<B**, **C>**, and  $\blacksquare$  keys {page 7} can be programmed with the functions listed below. Please contact your dealer for further details on these functions.

- Auto Reply Message <sup>1</sup>
- AUX A
- AUX B
- Call
- Call Address Down <sup>2</sup>
- Call Address Up <sup>2</sup>
- Clear
- Clock
- Conventional
- Dialing
- Dialing Mode <sup>3</sup>
- Emergency <sup>4</sup>
- GPS Position Display <sup>5</sup>
- Home Address
- Horn Alert
- LCD Brightness
- Network Select
- None
- Playback <sup>1</sup>
- Public Address
- Redial
- Scrambler
- Send the GPS Data
- Site Lock
- Status/ Stack <sup>6</sup>
- Sub LCD Display
- Transceiver Password

<sup>1</sup> “Auto Reply Message” and “Playback” can be programmed only when the optional VGS-1 board has been installed.

<sup>2</sup> “Call Address Down” and “Call Address Up” can be programmed only on the optional microphone A, B, C, and D keys.

<sup>3</sup> “Dialing Mode” can be selected when Keypad Operation is set to Programmable.

<sup>4</sup> “Emergency” can be programmed only on the  $\triangle$  key.

<sup>5</sup> “GPS Position Display” can be assigned only if one of the COM ports is configured for GPS.

<sup>6</sup> “Status/Stack” can be programmed only on the S key.

## SEARCHING FOR A CONTROL CHANNEL

After switching the power ON, press any key while the power-on text or unit number is displayed to begin searching for a control channel.

- If no action is performed for 2 seconds, the transceiver will automatically begin searching for a control channel.
- “---” appears on the sub-display and an arrow scrolls across the main display while the transceiver is searching for a control channel.
- If more than one network is available, press the key programmed as **Network Select** to manually change networks.

## VOICE CALLS

### ■ MAKING A VOICE CALL

- 1 Press the  $\wedge$  and  $\vee$  keys (**Call Address Up / Call Address Down**) to select your desired call address.
- 2 Press the **Call** key or the **PTT** switch to initiate the call.
  - “CALLING” appears on the main display and “SVC” appears on the sub-display.
- 3 When the call is connected, a timer appears on the display.
  - The timer can be set to either count up (increasing number) or down (decreasing number).
- 4 Press the **PTT** switch to transmit; release it to receive.
  - The LED lights red while transmitting.
  - The sub-display shows your transmit power. A single triangle ( $\blacktriangle$ ) represents low power and dual triangles ( $\blacktriangle\blacktriangle$ ) represents high power.
- 5 Press the **Clear** key to end the call. If the call time expires before you press the **Clear** key, the call will be automatically terminated.
  - “END” momentarily appears on the display before returning to the call address of the call you just made.

### ■ RECEIVING A VOICE CALL

- 1 When a call is received, the caller’s unit number appears on the main display.
  - If you have the caller’s address set up in your transceiver, the call address is displayed instead of the unit number.
  - Depending on the type of call being received, a code will appear on the sub-display:
    - CAL*: An individual call is being received.
    - GRP*: A group conference call is being received.
    - BCC*: A group broadcast call is being received.
  - Special calls are denoted as follows:
    - I-FLEET*: A call from a different fleet (Inter-Fleet).
    - I-PREFIX*: A call from a different prefix (Inter-Prefix).
    - PABX*: A call from a PABX telephone system.
    - PSTN*: A call from a PSTN telephone system.
- 2 Press the **PTT** switch to respond to the call.
  - The remaining call time appears on the display.
- 3 When the call ends, the display returns to the call address that was previously displayed. However, if you end the call by pressing the **Clear** key, “END” momentarily appears on the display before returning to the call address.





## STATUS CALLS

### ■ MAKING A STATUS CALL

- 1 Press the  $\wedge$  and  $\vee$  keys (**Call Address Up / Call Address Down**) to select your desired call address.
- 2 Press the **Status/ Stack** key (default is the **S** key), then press the  $\wedge$  and  $\vee$  keys to select your desired status.
  - The status number appears on the sub-display.
- 3 Press the **Call** key (or **PTT** switch if “PTT to Initiate Call” has been programmed) to send the status.
  - “CALLING” appears on the display.
- 4 When the status has been received by the called party, “COMPLETE” momentarily appears on the display before returning to the previously selected call address.

### ■ RECEIVING A STATUS/SHORT DATA MESSAGE CALL



- 1 When a call is received, the  icon appears on the display and flashes.
  - The  icon remains on the display when there is data in the stack.
- 2 To view the status or message, refer to “Viewing the Stack”, on page 12.

## DATA CALLS

### ■ MAKING A DATA CALL

- 1 Enter control code  $\star$  2 to make a SDM (Short Data Message) call.
- 2 Press the  $\star$  key, then enter your message.
  - Enter characters using the keypad or by pressing the  $\wedge$  and  $\vee$  keys. When pressing the  $\wedge$  and  $\vee$  keys, press the **<B** or **<C>** key to set the selected character.
  - To clear a character, press the **Clear** key. To clear all entered characters, press and hold the **Clear** key.
- 3 Press the  $\star$  key to end your message.
- 4 Enter the ID number of the unit you want to send the message to.
- 5 Press the **PTT** switch, the **Call** key, or the **#** key to transmit.

### ■ RECEIVING A DATA CALL

- 1 When a call is received, the  icon appears on the display and flashes.
  - The  icon remains on the display when there is data in the stack.
- 2 To view the message, refer to “Viewing the Stack”, on page 12.

## CALL DISPLAYS

The following messages may appear on the display under certain circumstances:

- *ENGAGED*: The called party is in another call.
- *HOLDING*: The transceiver is confirming the call made by the base station.
- *INVALID*: You entered an invalid call address.
- *NU*: The called party could not be reached (Number Unobtainable).
- *NO REPLY*: The called party has been called, but they did not respond to the call.
- *PARTY BUSY*: The called party is temporarily prohibited from making calls.
- *QUEUED*: All communication channels are currently in use; your call will be connected when a channel becomes free.

## VIEWING THE STACK

- 1 Press the **Status/ Stack** key (default is the **S** key) twice to enter the stack.
  - If there is no data in the stack, “-----” appears on the main display and “-00” appears on the sub-display.
- 2 Press the **∧** and **∨** keys to view the stack entries.
  - “NEW” momentarily appears on the sub-display if the message has not yet been viewed.
  - In the sub-display, “S” represents a status stack entry, “V” represents a voice stack entry, and “D” represents a data stack entry.
- 3 Press the **<B** and **C>** keys to scroll through the selected entry, to view the entire entry. Press the **A** key to toggle between the time/date of the received call and the caller ID.
- 4 To erase an entry, select the desired entry and press the **Clear** key.
  - “DELETE?” appears on the display. Press the **S** or **✖** key to confirm the deletion. Press the **A** or **#** key to cancel.
- 5 To erase all entries, press and hold the **Clear** key.
  - “DELETE?” appears on the main display and “ALL” appears on the sub-display. Press the **S** or **✖** key to confirm the deletion. Press the **A** or **#** key to cancel.

## CALL DIVERTING

### ■ DIVERTING YOUR OWN CALLS

- 1 Enter control code **\*41** to divert your calls to a different transceiver.
- 2 Press the **\*** key, then enter the ID number of the unit to where you want your calls diverted.
- 3 Press the **PTT** switch, the **Call** key, or the **#** key to set up the call diversion.
  - “CALLING” appears on the display.
  - When the call divert is set, “COMPLETE” momentarily appears on the display. Additionally, the  icon appears on the display and flashes.
- 4 To end the call diversion, enter control code **#41**, then press the **PTT** switch, the **Call** key, or the **#** key.
  - “CALLING” appears on the display.
  - When the call divert is cleared, “COMPLETE” momentarily appears on the display.

### ■ DIVERTING THIRD PARTY CALLS

- 1 Enter control code **\*44** to divert third party calls.
- 2 Press the **\*** key, then enter the ID number of the unit from which you want calls diverted.
- 3 Press the **\*** key, then enter the ID number of the unit to where you want the calls diverted.
- 4 Press the **PTT** switch, the **Call** key, or the **#** key to set up the call diversion.
  - “CALLING” appears on the display.
  - When the call divert is set, “COMPLETE” momentarily appears on the display.
- 5 To end the call diversion, enter control code **#44** followed by the **\*** key and the ID number of the unit from which calls are being diverted, then press the **PTT** switch, the **Call** key, or the **#** key.
  - “CALLING” appears on the display.
  - When the call divert is cleared, “COMPLETE” momentarily appears on the display.

## DIALING MODE

Press the key programmed as **Dialing Mode** to enter a dialing number using the keypad.

---

**Note:** You can select **Dialing Mode** when Keypad Operation is set to Programmable.

---

## KEYPAD ENTRY

Besides using the  $\wedge$  and  $\vee$  keys, you can enter dialing codes manually, by entering the numbers using the microphone keypad.

- Refer to the dialing codes listed in the appendix, starting on page 25.

## ■ REDIALING

If a key has been programmed with **Redial** (default is the **A** key), you can easily redial previously dialed call addresses.

### Redial:

- 1 Press the key programmed as **Redial**.
- 2 Press the  $\wedge$  and  $\vee$  keys to select 1 of the 3 last dialed numbers.
- 3 Press the **Call** key or the **PTT** switch to initiate the call.

## EMERGENCY CALLS

If your transceiver has been programmed with the Emergency function, you can make emergency calls.

---

**Note:** Only the  $\triangle$  key can be programmed with the Emergency function.

---

Press and hold the key programmed as **Emergency**.

- Depending on the delay time programmed into your transceiver, the length of time you must hold the **Emergency** key will vary.

## PUBLIC ADDRESS (PA)

If your transceiver is connected to an external PA speaker, you can use the transceiver as a Public Address system.

- 1 Press the key programmed as **Public Address**.
  - The  $\odot$  icon appears on the display while the PA system is active.
- 2 Press the microphone **PTT** switch, then speak into the microphone.
  - Press the  $\wedge$  and  $\vee$  keys (**Volume Up / Volume Down**) to adjust the audio output from the external speaker.
- 3 Press the **Public Address** key again to return to normal operation.

## HORN ALERT



If your transceiver is connected to your vehicle horn or other external device, this function can alert you of an incoming call when you are away from your vehicle.

Toggle Horn Alert ON and OFF by pressing the key programmed as **Horn Alert**.

- The  $\boxtimes$  icon appears on the display while Horn Alert is active.

## AUXILIARY PORT

If a key has been programmed with the **AUX A** or **AUX B** function, you can press that key to turn the Auxiliary Port on and off.

- When Auxiliary Port A is activated, the AUX A indicator (  ) appears on the display.
- When Auxiliary Port B is activated, the AUX B indicator (  ) appears on the display.

## GPS REPORT

If a GPS unit (NMEA-0183 format) is installed on your transceiver and the **Send the GPS Data** function has been programmed onto a key by your dealer, press the **Send the GPS Data** key to send your location data.

## HOME ADDRESS

If a key has been programmed with the Home Address function, you can press that key to jump to the pre-programmed call address.

- "HAD" appears in the sub-display when the selected call address is the Home Address

Press **Home Address** a second time to return to the previous call address you were using.

## SITE LOCK

Press and hold this key for 1 second to lock the Site. "SITE LOCKED" momentarily appears on the display. Press and hold this key again for 1 second to cancel Site Lock.

## SUB-LCD DISPLAY

If a key has been programmed with the **Sub-LCD Display** function, you can press that key to toggle the sub-display between "SVC", the current control channel number, and the signal strength readout.

## SWITCHING TO CONVENTIONAL MODE

Depending on how your transceiver is programmed, you can enter Conventional Mode in one of two ways:

*Manual:* When in Trunking Mode, press the key programmed as **Conventional** to change the operating mode. This function only works when no signals are currently being received.

*Auto:* The transceiver automatically changes to Conventional Mode when you are outside the network area.

# CONVENTIONAL MODE



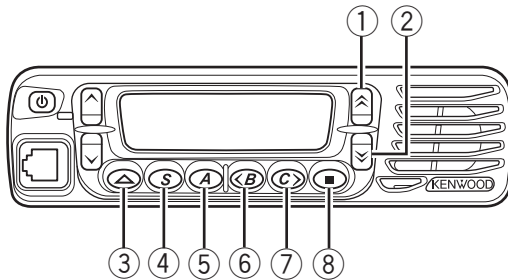



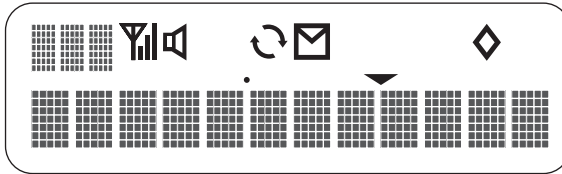

## KEY FUNCTIONS



- ① **↑ key**  
Press to increase the channel number.
- ② **↓ key**  
Press to decrease the channel number.
- ③ **▲ key**  
Press to activate its programmable function {page 18}.  
The default setting is Squelch Off.
- ④ **S key**  
Press to activate its programmable function {page 18}.  
The default setting is Scan.
- ⑤ **A key**  
Press to activate its programmable function {page 18}.  
The default setting is Scan Delete/Add.
- ⑥ **<B key**  
Press to activate its programmable function {page 18}.  
The default setting is LCD Brightness.
- ⑦ **C> key**  
Press to activate its programmable function {page 18}.  
The default setting is Clock.
- ⑧ **■ key**  
Press to activate its programmable function {page 18}.  
The default setting is Clear.

## DISPLAY



Indicator	Description
	Displays channel numbers (or names) and received messages.
	Displays channel numbers and transceiver functions.
	Displays the strength of received signals. An antenna and all 3 strength bars represents strong signals while the antenna by itself (no strength bars) represents weak signals.
	Appears when the Squelch Off function has been activated (squelch has been turned off).
	Appears while scanning.
	Flashes when you receive a message. Lights when a message is stored in the queue memory.
	Appears when the Scrambler function is activated.
	Appears when the Auto Recording function on the VGS-1 option is activated.
	Appears when the selected channel is added to the scanning sequence.





## ■ SCAN REVERT

During scan, when pressing the **PTT** switch, you can transmit on the revert channel. Four types of Scan Reverts which can be programmed by your dealer are available.

- **Last Called:** The last channel on which you received a call.
- **Last Used:** The last channel to which you responded.
- **Selected:** The channel you selected prior to activating Scan.
- **Selected + Talkback:** The channel you selected prior to activating Scan is the revert channel. However, you can respond (talkback) to a call if you are currently receiving on a different channel.

## SQUELCH OFF

Press the **Squelch Off** key (default key is  $\triangle$ ) to listen to weak signals that you cannot hear during normal operation and to adjust the volume when no signals are present on your selected channel.

- The  $\triangle$  icon appears and the Busy LED lights green while Squelch Off is activated.

Press **Squelch Off** again to return to normal operation.

## EMERGENCY (TRUNKING)

The Emergency (Trunking) function will place an Emergency Call (page 14) when entering Trunking mode.

- This function can be configured only when Trunking Search Delay Time is not set to "Off" and Automatic Mode Change is set to "Alert".
- Emergency (Trunking) cannot be used if the Trunking Search has not found a Control Channel.

---

**Note:** Only the  $\triangle$  key can be programmed with the Emergency function.

---

Press and hold the key programmed as **Emergency (Trunking)**.

## QUIET TALK (QT)/ DIGITAL QUIET TALK (DQT)

Your dealer may have programmed QT or DQT signaling on your transceiver channels. A QT tone/ DQT code is a sub-audible tone/code which allows you to ignore (not hear) calls from other parties who are using the same channel.

When a channel is set up with a QT tone or DQT code, squelch will open only when a call containing a matching tone or code is received. Likewise, signals you transmit will be heard only by parties whose QT/ DQT signaling matches your transceiver.

If a call containing a different tone or code is made on the same channel you are using, squelch will not open and you will not hear the call. Although it may seem like you have your own private channel while using QT/ DQT, other parties can still hear your calls if they set up their transceiver with the same tone or code.

## TIME-OUT TIMER (TOT)

The purpose of the Time-out Timer is to prevent any caller from using a channel for an extended period of time.

If you continuously transmit for a period of time that exceeds the programmed time set by your dealer (default is 1 minute), the transceiver will stop transmitting and an alert tone will sound. To stop the tone, release the **PTT** switch.

Your dealer can program the TOT time in the range of 15 seconds to 20 minutes.

## BUSY CHANNEL LOCKOUT (BCL)

When activated, BCL prevents you from interfering with other parties who may be using the same channel that you selected. Pressing the **PTT** switch while the channel is in use will cause your transceiver to emit an alert tone and transmission will be inhibited (you cannot transmit). Release the **PTT** switch to stop the tone and return to receive mode.

## SWITCHING TO TRUNKING MODE

Depending on how your transceiver is programmed, you can return to Trunking Mode in one of three ways:

*Manual:* Press the **Clear** key (default key is ■) to change the operating mode.

*Auto:* While in Conventional Mode, the transceiver periodically searches for the network. When it finds the network, the transceiver automatically changes to Trunking Mode. An alert tone sounds to notify you when the operating mode changes.

*Alert:* While in Conventional Mode, the transceiver periodically searches for the network. When it finds the network, an alert tone sounds. Press the **Clear** key (default key is ■) to change the operating mode.

# ADVANCED & BACKGROUND OPERATIONS

## SCRAMBLER

Although the scrambler function does not offer complete privacy with your calls, it does prevent others from easily listening in on your calls. When activated, the transceiver distorts your voice so that anybody listening to your call will be unable to clearly hear what you are saying.

In order for members of your own group to clearly hear your call while you are using the scrambler, all other members must also activate the scrambler functions on their transceivers. This distorts everybody's voice while transmitting and corrects the voice message on your own transceiver when you receive the call.

To activate the scrambler, press the key programmed as **Scrambler**.

- The  icon appears on the display while the scrambler is active.

To deactivate the scrambler, press the **Scrambler** key again.

---

**Note:** There are 2 options for using the scrambler. Your dealer can activate or deactivate the built-in scrambler function of the transceiver, or they can add a more secure optional scrambler board to your transceiver. Ask your dealer for details.

---

## DTMF (DUAL TONE MULTI FREQUENCY) CALLS

Press and hold the **PTT** switch, then enter the desired digits using the front panel keypad.

- If you release the **PTT** switch, transmit mode will end even if the complete number has not been sent.

## GPS POSITION DISPLAY

If a GPS unit (NMEA-0183 format) is installed on your transceiver and the **GPS Position Display** function has been programmed onto a key by your dealer, press the **GPS Position Display** key to display latitudinal, longitudinal and altitudinal values on the main display of the transceiver.

## LCD BRIGHTNESS

The LCD backlight can be turned off or set to low or high levels. To cycle through the brightness settings, press the key programmed as **LCD Brightness**.

- Each press of LCD Brightness cycles the brightness level from high to low to off and then back to high.

## CLOCK

If activated by your dealer, your transceiver can track the time and date with its built-in clock. To view the clock any time, press the key programmed as **Clock**.

If programmed by your dealer, the time will display momentarily when the transceiver power is turned ON.

---

**Note:** Removing the transceiver power for extended periods will cause the clock time to clear.

---

### ■ CLOCK SETUP

To set the year, month, day, and time:





- 1 With the transceiver power OFF, press and hold the **C>** key while turning the transceiver power ON.
  - The current year setting appears.



- 2 Press the **∧** and **∨** keys to select the year, then press the **S** key to cycle to the month setting.
  - Repeat this step, to cycle through the day, hour, and minute settings.
- 3 Press the **S** key again, to return to the year setting.
  - A triple beep will sound, indicating that your selections have been set into the transceiver memory.
- 4 Turn the transceiver power OFF and then back ON to return to normal operation.

### SIGNAL STRENGTH INDICATOR

The signal strength indicator displays the strength of received calls:

-  Strong signal
-  Medium signal
-  Weak signal
-  Very weak signal

# VGS-1 OPTIONAL VOICE GUIDE & STORAGE UNIT

When using the optional VGS-1 voice guide & storage unit, you gain access to the voice recorder and voice announcement functions. Ask your dealer for details.

---

**Note:** The VGS-1 is sold depending upon area.

---

## VOICE RECORDER

The voice recorder function allows you to record your conversations and create voice memos and automated message responses.

### ■ AUTO RECORDING

If activated, the auto recording function will continuously record all transmitted and received signals. The recording storage area retains 30 seconds of recording, so all transmitted and received signals are simultaneously recorded and erased, leaving only the last 30 seconds of recording in memory.

- The auto recording indicator (■■■■■■■■■■) appears when this function is activated.

### ■ VOICE MEMOS

To record a voice memo, for later playback:

- 1 Press and hold the key programmed as **Playback** for 1 second.
  - The duration of recording memory will appear on the display and begin counting down.
- 2 Speak into the microphone to record your voice memo.
- 3 Press the ■, **S**, or \* key to end the recording at any time and store it into the transceiver memory.
  - If the memory becomes full, recording will stop automatically and store the voice memo to memory.
  - "WRITING" appears on the display while the recording is being stored to memory.

### ■ AUTO REPLY MESSAGE (TRUNKING MODE ONLY)

You can set the transceiver to automatically respond to Individual Calls:

- 1 Press the key programmed as **Auto Reply Message** to enter Auto Reply Message mode.
  - The Auto Reply Message indicator (■■■■■■■■■■) appears on the display.
- 2 When you receive an Individual Call, Auto Reply will begin after waiting for 3 seconds, the transceiver will send an automatic response to the caller, and "GREETING" appears on the display.
  - If you are available to receive the call, press any key to disable the auto response.

- If memory is available on your transceiver for recording, “I am not available. Leave your Message.” will be sent to the caller. The caller can then leave a recorded message on your transceiver which you can later recall and listen to. When a message is stored on your transceiver, “MSG RCVD” appears on the display.
- If no memory is available on your transceiver for recording, “I am not available.” will be sent to the caller and “MEMORY FULL” appears on the display.

## ■ **PLAYBACK**

To play back a recorded conversation, memo, or message:

- 1 Press the key programmed as **Playback** to enter Playback mode.
  - If the last action on your transceiver was to auto record your conversation, “STORE?” will appear on the display, otherwise a recording channel with the time of the recording will appear.
  - To store the conversation record in the next available recording channel, press the **■** key. To clear the conversation, press the **A** or DTMF # key. To skip to the stored recording channels, press the **S** or DTMF ✕ key. To skip back 5 seconds, press the **<B** key. To skip ahead 5 seconds, press the **C>** key.
- 2 Press the **⤴** and **⤵** keys to select the channel which you want to play back.
  - “RM” represents automated reply messages.
  - “AR” represents conversation records.
  - “VM” represents voice memos.
- 3 The transceiver will announce the channel, then the recording will automatically play back.
  - When the entire recording has been played, “END OF MSG” (end of message) is displayed.
  - To delete the selected recording, press the **A** or DTMF # key. To clear all the recorded data, press and hold the **A** or DTMF # key. A confirmation message will appear on the display; press the **S** or DTMF ✕ key to delete the recording(s) or the **A** or DTMF # key to cancel.

## **VOICE GUIDE**

When pressing a transceiver key, an audio voice will announce the key function. If programmed by your dealer, an audio voice will also announce the selected call address, when changing call addresses.

# APPENDIX

## 2 Digit Dialing

Function	Dial String
Individual number	20 ~ 89
Group number	90 ~ 99

## 3 Digit Dialing

Function	Dial String
Individual number	200 ~ 899
Group number	900 ~ 998
Emergency operator	112, 999
Enter the open channels	101 ~ 110
Network operator services	100, 111, 121, 131, 141, 151, 161, 171, 181, 191

## 4 Digit Dialing

Function	Dial String
PABX call	1000 ~ 8999

## 5 Digit Dialing

Function	Dial String
PABX call (single address word calls)	First string (3 ~ 6) + Second string (1000 ~ 8999)
PABX call (extended addressing protocol)	First string (0, 7, or 8) + Second string (0000 ~ 9999)

## 6 Digit Dialing

Function	Dial String
Common prefix Inter-fleet individual call	Fleet # (2001 ~ 6050) + Individual # (20 ~ 89)
Common prefix Inter-fleet group call	Fleet # (2001 ~ 6050) + Group # (90 ~ 99)
PABX call (extended addressing protocol)	First string (0, 7, or 8) + Second string (00000 ~ 99999)

## 7 Digit Dialing

Function	Dial String
Common prefix Inter-fleet individual call	Fleet # (2001 ~ 6050) + Individual # (200 ~ 899)
Common prefix Inter-fleet group call	Fleet # (2001 ~ 6050) + Group # (900 ~ 998)
PABX call (extended addressing protocol)	First string (0, 7, or 8) + Second string (000000 ~ 999999)

## 8 Digit Dialing

Function	Dial String
PSTN call	First string (0) + Second string (0000000 ~ 9999999)
PABX call (extended addressing protocol)	First string (7 or 8) + Second string (0000000 ~ 9999999)

## 9 Digit Dialing

Function	Dial String
Inter-prefix Inter-fleet individual call	Prefix # (200 ~ 327) + Fleet # (2001 ~ 6050) + Individual # (20 ~ 89)
Inter-prefix Inter-fleet group call	Prefix # (200 ~ 327) + Fleet # (2001 ~ 6050) + Group # (90 ~ 99)
PSTN call	First string (0) + Second string (00000000 ~ 99999999)
PABX call	First string (7 or 8) + Second string (00000000 ~ 99999999)

## 10 Digit Dialing

Function	Dial String
Inter-prefix Inter-fleet individual call	Prefix # (200 ~ 327) + Fleet # (2001 ~ 6050) + Individual # (200 ~ 899)
Inter-prefix Inter-fleet group call	Prefix # (200 ~ 327) + Fleet # (2001 ~ 6050) + Group # (900 ~ 998)
PSTN call	First string (0) + Second string (000000000 ~ 999999999)

## 11 ~ 31 Digit Dialing (Common)

Function	Dial String
PSTN call	First string (0) + Second string (0000000000 ~ 9999999999 99999999999999999999)

**Note:** A maximum of 31 digits consisting of a 1-digit first string and a 10- to 30-digit second string can be used for a dial string.



Control Codes

Function	Dial String
Call setup abandoned, call complete	* #
Send status for dispatcher (status 0)	* 0
Send status for dispatcher (status nn)	* 0nn
Group call (Conference call)	* 1
Group call (Broadcast call)	* 11
Priority voice system-wide-call	* 1981#
Emergency voice system-wide-call	* 1982#
Priority np data system-wide-call	* 1983#
Emergency np data system-wide-call	* 1984#
Short data system-wide-call	* 1985#
Standard voice system-wide-call	* 1987#
Short data on the control channel	* 2
Divert own calls (voice & data, voice only, data only)	* 41,* 411,* 412
Divert third party calls (voice & data, voice only, data only)	* 44,* 441,* 442
Queue incoming calls	* 48#
Don't disturb (voice & data, voice only, data only)	* 49#,* 491#,*492#
Priority call	* 8
Emergency call	* 9
End dialed string	#
Send status for dispatcher (status 31)	#0
Cancel divert own calls (voice & data, voice only, data only)	#41#, #411#, #412#
Cancel divert third party calls (voice & data, voice only, data only)	#44, #441, #442
General cancellation by recipient	#45#, #451#, #452#
Cancel queue incoming calls	#48#
Cancel don't disturb (voice & data, voice only, data only)	#49#, #491#, #492#